

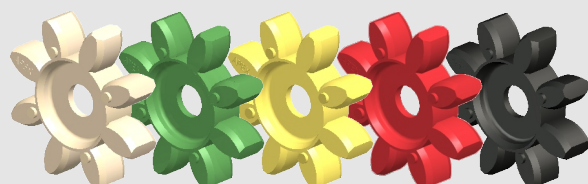

APEX DYNAMICS, INC.

Backlash-Free Servo Coupling

Elastomer Type

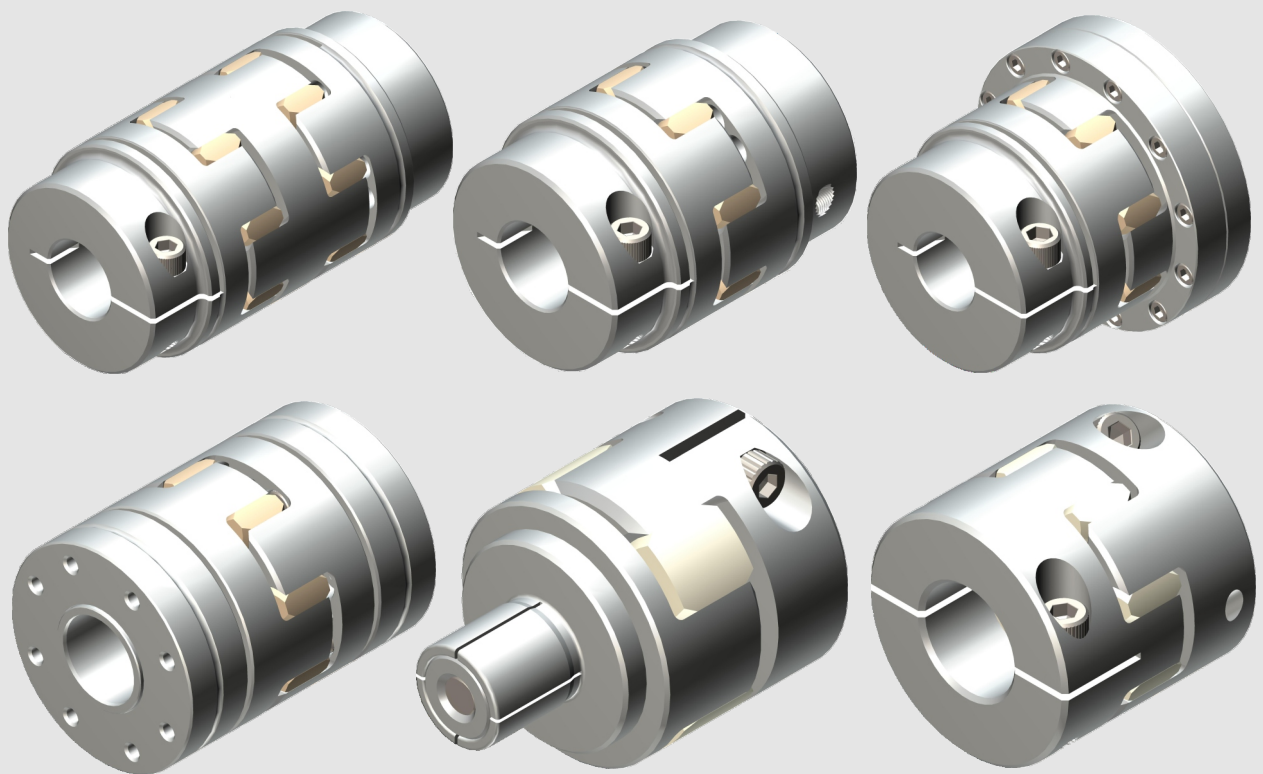

5 Years Warranty !

Coupling - Elastomer

▶ Features:

- ▶ Backlash Free / High Precision
- ▶ High Torque / High Speed
- ▶ Low Inertia
- ▶ Torsional Rigidity
- ▶ Permissible Eccentric Angle
- ▶ Shock Absorption / Motor High Gain
- ▶ High Frequency Reciprocating
- ▶ Servo / Stepper Motor
- ▶ Spindle Drive
- ▶ Input and Output Shaft Sleeve Type
- ▶ Easy Axial Installation

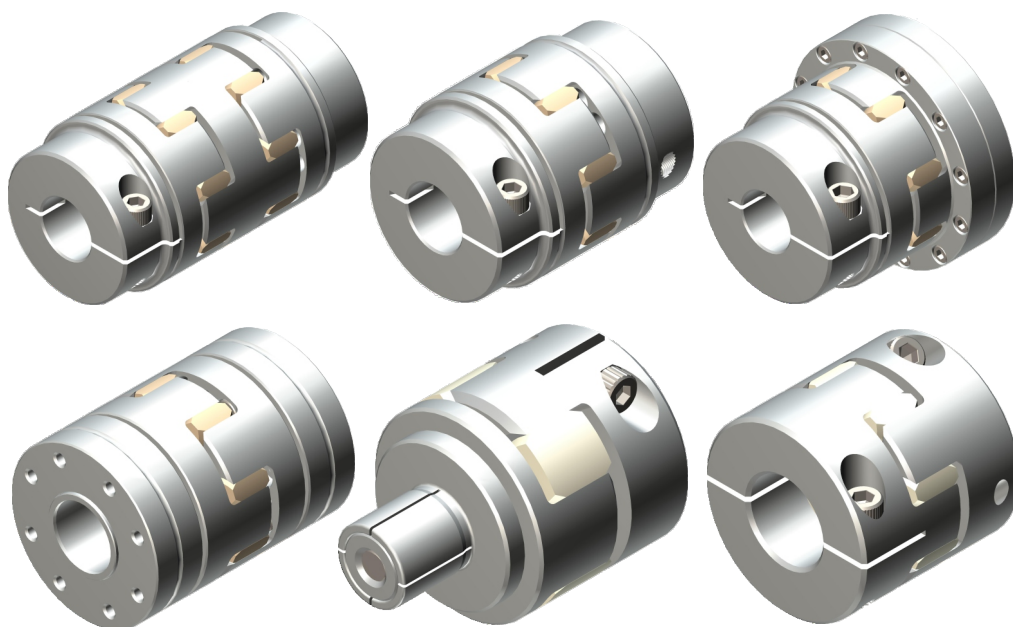

Ordering Code - Elastomer Coupling

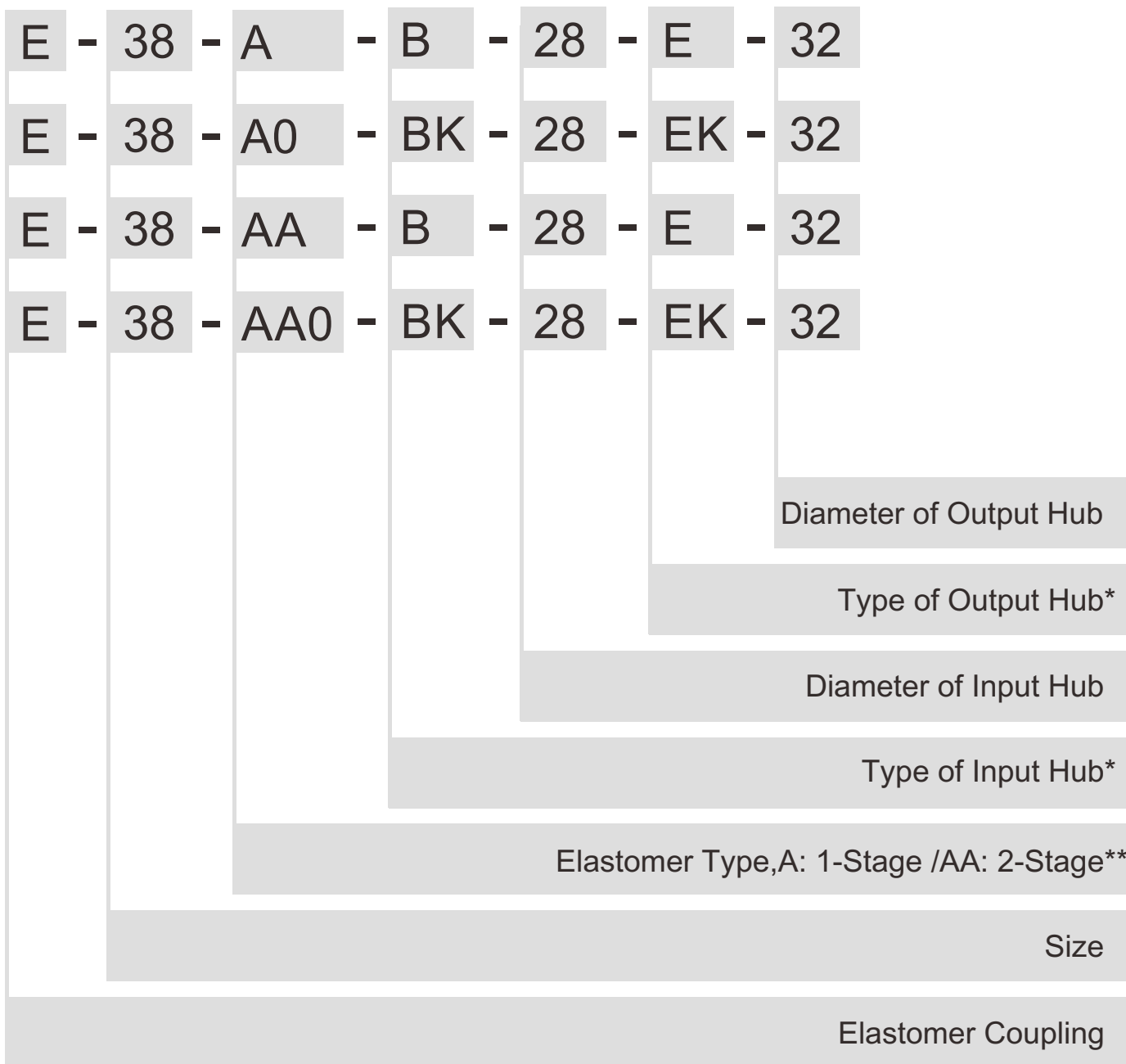

* " K " for Keyway

** " 0 " for Hollow. AA0: Both of the 2 A-type Elastomers in the 2-stage coupling are hollowed.



©2020 by APEX DYNAMICS, INC.
 APEX DYNAMICS, INC. reserves modification and copyrights of all technical specifications, illustrations and drawings in this catalog in allowance for continuous products development and advancement. For the newest data and information, please visit <http://www.apexdyna.com/>

Type of Hubs

A / AK Type

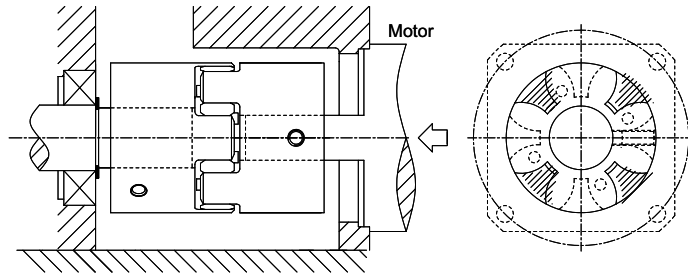
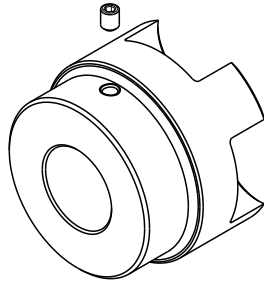

B / BK Type

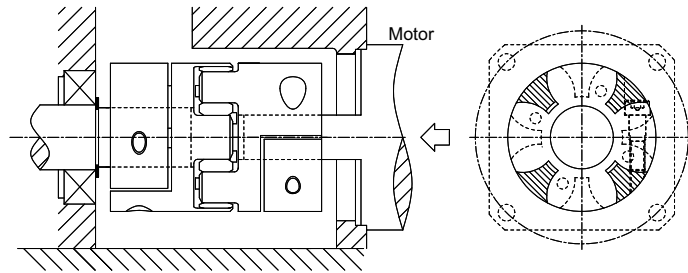
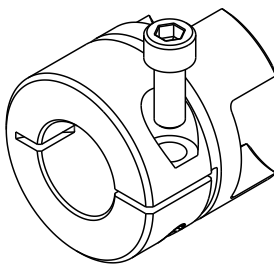

C / CK Type

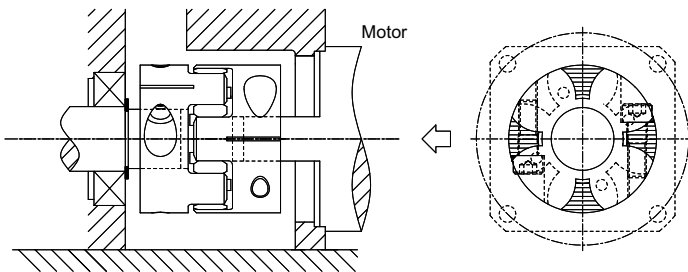
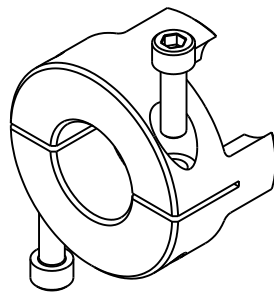

Type of Hubs

D Type

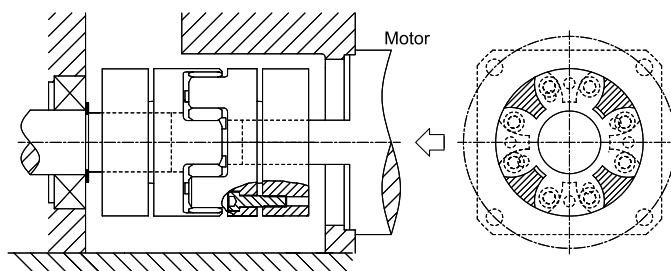
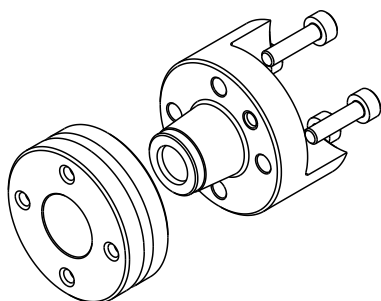

E / EK Type

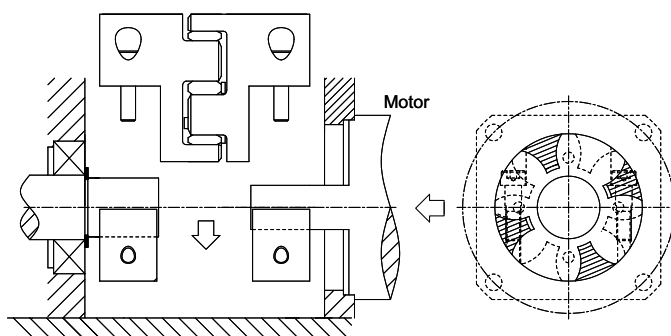
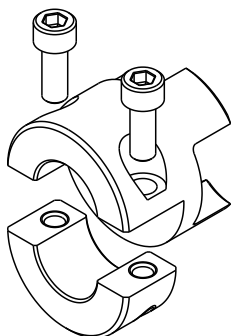

F Type

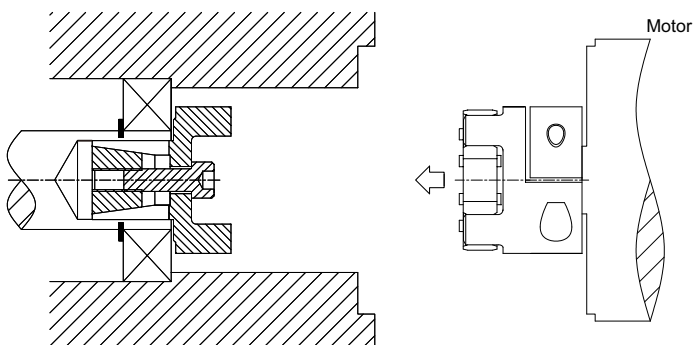
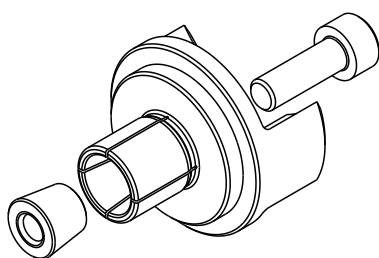

Type of Hubs

G Type

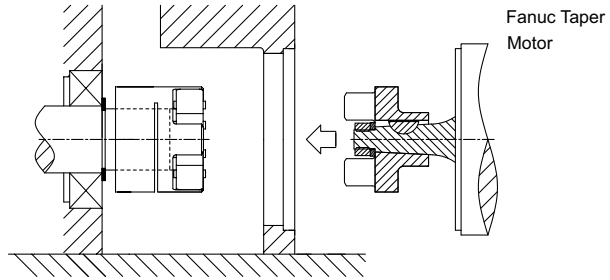
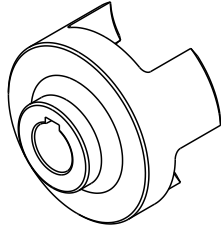

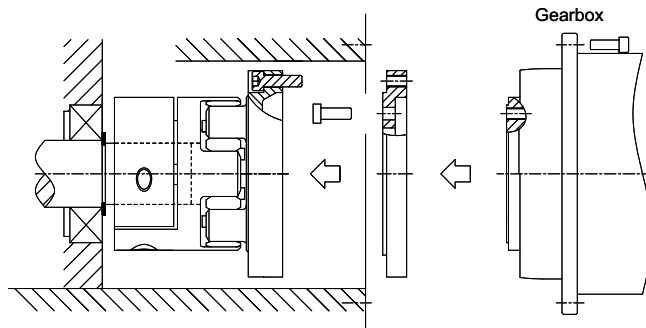
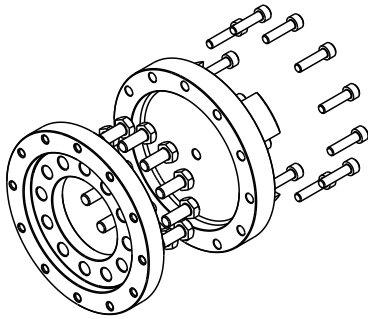

N Type

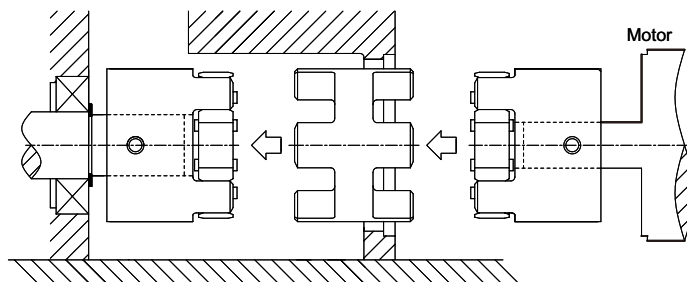
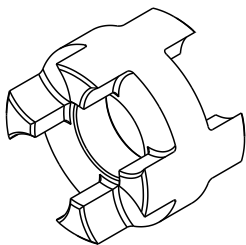

Q Type

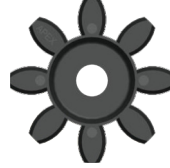
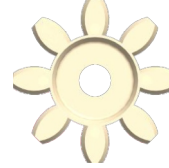

Elastomer Technical Data

Elastomer					
Type	A	B	C	D	E
Color	Green	Red	Yellow	Black	Cream
Hardness	64 Sh-D	98 Sh-A	80 Sh-A	65 Sh-D	64 Sh-D
Material	TPU	TPU	TPU	TPU	Hytrel
Temperature Range °C	-30 to +120	-30 to +100	-30 to +100	-10 to +70	-50 to +150
Size	07 to 90	07 to 90	07 to 19	07 to 90	07 to 90
Properties	High Rigidity Withstand High Ambient Temperature	High Damping Positioning Drive	Higher Damping Transmission of the measuring system	Conductive	High temperature resistance, High rigidity

Keyway Dimension

B	ØD2		B	ØD2	
2	>=6	<=8	14	>44	<=50
3	>8	<=10	16	>50	<=58
4	>10	<=12	18	>58	<=65
5	>12	<=17	20	>65	<=75
6	>17	<=22	22	>75	<=85
8	>22	<=30	25	>85	<=95
10	>30	<=38	28	>95	<=110
12	>38	<=44	32	>110	<=130

(1) Finish bore with keyway which >Ø6, acc. to DIN 6885/1 JS9.

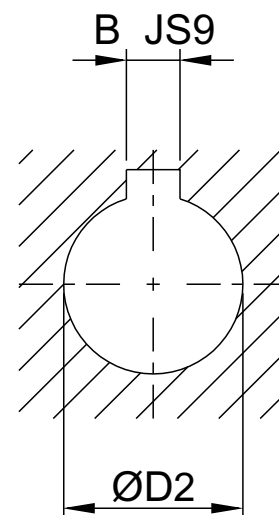

Elastomer Technical Parameter

Size	Type	Shore Hardness	Rated Torque T_{KN} [Nm]	Max. Torque T_{Kmax} [Nm]	Static Torsional Rigidity [Nm/rad] ⁽¹⁾	Dynamic Torsional Rigidity [Nm/rad] ⁽¹⁾	Radial Rigidity Cr [N/mm]
07	A / E	64Sh-D	2.4	4.8	34.3	103	630
	B	98Sh-A	2	4	22.9	69	421
	C	80Sh-A	0.7	1.4	8.6	26	114
08	A / E	64Sh-D	2.4	4.8	35.3	106	648
	B	98Sh-A	2	4	23.5	71	433
	C	80Sh-A	0.7	1.4	8.8	27	117
09	A / E	64Sh-D	6	12	74.6	224	739
	B	98Sh-A	5	10	51.6	155	518
	C	80Sh-A	1.8	3.6	17.2	52	125
12	A / E	64Sh-D	12	24	327.9	982	1198
	B	98Sh-A	9	18	240.7	718	846
	C	80Sh-A	3	6	84.3	252	274
13	A / E	64Sh-D	14.5	29	430	1287	1570
	B	98Sh-A	11	22	316	941	1109
	C	80Sh-A	3.6	7.2	111	330	359
14	A / E	64Sh-D	16	32	234.2	702	856
	B	98Sh-A	12.5	25	171.9	513	654
	C	80Sh-A	4	8	60.2	180	153
16	A / E	64Sh-D	19	38	612	1835	2238
	B	98Sh-A	15	30	450	1341	1710
	C	80Sh-A	5	10	157	471	400
19	A / E	64Sh-D	26	52	2560	3810	2930
	B	98Sh-A	21	42	1512	2540	2010
	C	80Sh-A	6	12	618	1065	582
24	A / E	64Sh-D	75	150	5030	10896	3696
	B	98Sh-A	60	120	3640	5980	2560
28	A / E	64Sh-D	200	400	10260	20177	4348
	B	98Sh-A	160	320	6410	9920	3200
38	A / E	64Sh-D	405	810	26300	40335	6474
	B	98Sh-A	325	650	11800	17160	4400
42	A / E	64Sh-D	560	1120	36860	69825	7270
	B	98Sh-A	450	900	21594	37692	5570
48	A / E	64Sh-D	655	1310	57630	99750	8274
	B	98Sh-A	525	1050	25759	45620	5930
55	A / E	64Sh-D	825	1650	105730	130200	9248
	B	98Sh-A	685	1370	42117	61550	6686
65	A / E	64Sh-D	1175	2350	118510	189189	8870
	B	98Sh-A	940	1880	48520	71660	6418
75	A / E	64Sh-D	2400	4800	182320	316377	11923
	B	98Sh-A	1920	3840	79150	150450	8650
90	A / E	64Sh-D	4500	9000	429450	908700	14700
	B	98Sh-A	3600	7200	204500	302900	10700

(1) The dynamic torsional rigidity is the value when the transmitted torque is $0.5 \times T_{KN}$.

(2) T_{KN}/T_{Kmax} is the torque force of elastomer, and connection between the shaft and coupling is checked by the customer.

Elastomer Displacements

Size	Shore Hardness	Displacements of Standard / 1-Stg.			Displacements of Q Type / 2-Stg.			
		Axial ⁽¹⁾ [mm]	Radial [mm]	Angle [degree]	Axial ⁽¹⁾ [mm]	Radial [mm]	Angle [degree]	
07	64Sh-D	+0.6	0.04	0.8°	+0.6	0.17	0.8°	
	98Sh-A	-0.3	0.06	0.9°		-0.6	0.19	0.9°
	80Sh-A		0.15	1.1°			0.23	1.1°
08	64Sh-D	+0.6	0.06	0.8°	-	-	-	
	98Sh-A	-0.1	0.08	0.9°				
	80Sh-A		0.15	1.1°				
09	64Sh-D	+0.8	0.05	0.8°	+0.8	0.21	0.8°	
	98Sh-A	-0.3	0.08	0.9°		-0.6	0.24	0.9°
	80Sh-A		0.19	1.1°			0.29	1.1°
12	64Sh-D	+0.9	0.05	0.8°	+0.9	0.25	0.8°	
	98Sh-A	-0.3	0.08	0.9°		-0.6	0.29	0.9°
	80Sh-A		0.20	1.1°			0.35	1.1°
13	64Sh-D	+0.9	0.05	0.8°	-	-	-	
	98Sh-A	-0.5	0.08	0.9°				
	80Sh-A		0.20	1.1°				
14	64Sh-D	+1.0	0.06	0.8°	+1.0	0.29	0.8°	
	98Sh-A	-0.4	0.09	0.9°		-0.8	0.33	0.9°
	80Sh-A		0.21	1.1°			0.4	1.1°
16	64Sh-D	+1.0	0.08	0.8°	-	-	-	
	98Sh-A	-0.5	0.10	0.9°				
	80Sh-A		0.21	1.1°				
19	64Sh-D	+1.2	0.04	0.8°	+1.2	0.36	0.8°	
	98Sh-A	-0.6	0.06	0.9°		-1.2	0.41	0.9°
	80Sh-A		0.15	1.1°			0.49	1.1°
24	64Sh-D	+1.4	0.07	0.8°	+1.4	0.47	0.8°	
	98Sh-A	-0.7	0.10	0.9°		-1.4	0.53	0.9°
28	64Sh-D	+1.5	0.08	0.8°	+1.5	0.53	0.8°	
	98Sh-A	-0.7	0.11	0.9°		-1.4	0.60	0.9°
38	64Sh-D	+1.8	0.09	0.8°	+1.8	0.61	0.8°	
	98Sh-A	-0.9	0.12	0.9°		-1.8	0.69	0.9°
42	64Sh-D	+2.0	0.10	0.8°	+2.0	0.67	0.8°	
	98Sh-A	-1.0	0.14	0.9°		-2.0	0.75	0.9°
48	64Sh-D	+2.1	0.11	0.8°	+2.1	0.73	0.8°	
	98Sh-A	-1.0	0.16	0.9°		-2.0	0.82	0.9°
55	64Sh-D	+2.2	0.12	0.8°	+2.2	0.81	0.8°	
	98Sh-A	-1.1	0.17	0.9°		-2.2	0.91	0.9°
65	64Sh-D	+2.6	0.13	0.8°	-	-	-	
	98Sh-A	-1.3	0.18	0.9°				
75	64Sh-D	+3.0	0.15	0.8°	-	-	-	
	98Sh-A	-1.5	0.21	0.9°				
90	64Sh-D	+3.4	0.17	0.8°	-	-	-	
	98Sh-A	-1.5	0.23	0.9°				

(1) The value of axial displacements has to be added to the length of the corresponding coupling type. The allowable displacement can only be used alone. If there are displacements in all three directions, the proportion of each deviation must be limited, when installing, keep the distance of SL4 as far as possible to ensure that the axial clearance of the coupling can be maintained during operation.

A / AK Type Hub

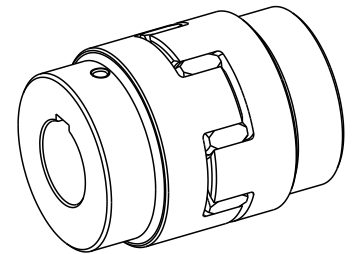
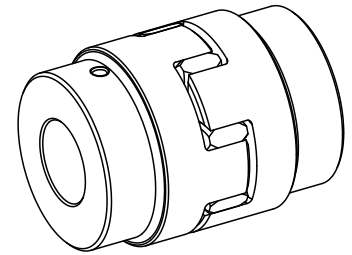
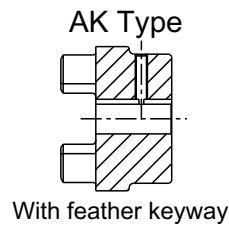
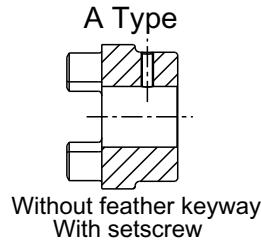
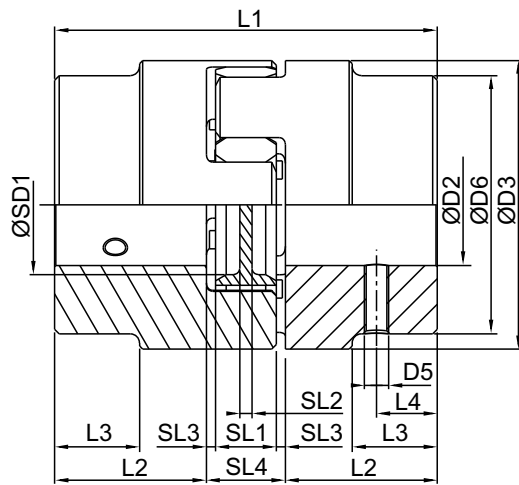

Spec 07-38 Hub Material - Aluminum.

Spec 42-90 Hub Material - Steel.

Size	Max. Speed [rpm]	D2 max	D3	D6	L1	L2	L3	SD1	SL1	SL2	SL3	SL4	Screw Tightening Torque T_A [Nm]	D5 ⁽²⁾	L4	Inertia ⁽³⁾ J [kg.cm ²]
07	34100	7	14	-	22	7	-	-	6	-	1	8	0.6	M3	3.5	0.001
09	23800	11	20	-	30	10	-	7.2	8	1.5	1	10	1.5	M4	5	0.005
12	19100	12	25	-	34	11	-	8.5	10	3.5	1	12	1.5	M4	5	0.015
14	15900	16	30	-	35	11	-	8.3	10	2	1.5	13	1.5	M4	5	0.029
19	11900	24	40	-	66	25	-	18	12	3	2	16	2	M5	10	0.194
24	8650	32	55	-	78	30	-	27	14	3	2	18	2	M5	10	0.787
28	7350	38	65	-	90	35	-	30	15	4	2.5	20	10	M8	15	1.785
38	5950	45	80	-	114	45	-	38	18	4	3	24	10	M8	15	5.148
42	5000	55	95	85	126	50	28	46	20	4	3	26	10	M8	20	25.301
48	4550	62	105	95	140	56	32	48	21	5	3.5	28	10	M8	20	42.28
55	3950	74	120	110	160	65	37	60	22	4.5	4	30	17	M10	20	84.886
65	3500	80	135	115	185	75	47	65	26	5.5	4.5	35	17	M10	20	132.946
75	2950	95	160	135	210	85	53	80	30	5	5	40	17	M10	25	288.939
90	2380	110	200	160	245	100	62	100	34	9.5	5.5	45	40	M12	30	772.73

(1) Elastomers with different hardnesses can be found on page 6.

(2) Set screws DIN EN ISO 4029.

(3) The moment of inertia of the maximum bore diameter of a single hub.

(4) Finished bore diameter tolerance is H7, bore diameter >Ø6 keyway, according to DIN 6885/1, dimensional tolerance is JS9. Please refer to page 6 for keyway dimensions corresponding to each bore diameter.

B / BK Type Hub

B Type, Size 07-14

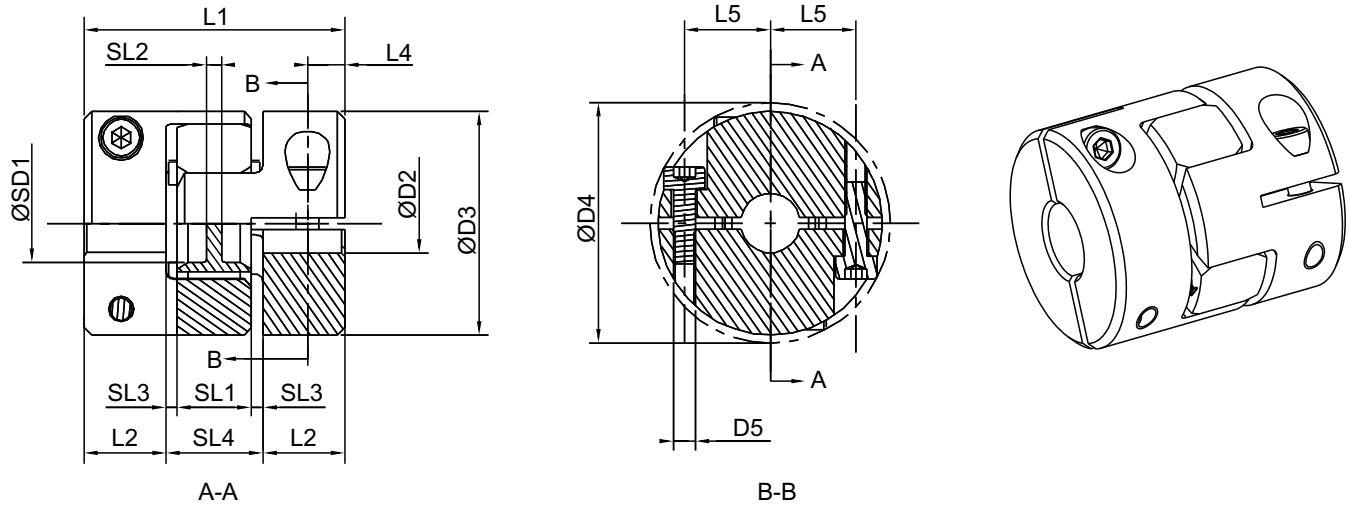

B Type, Size 19-38

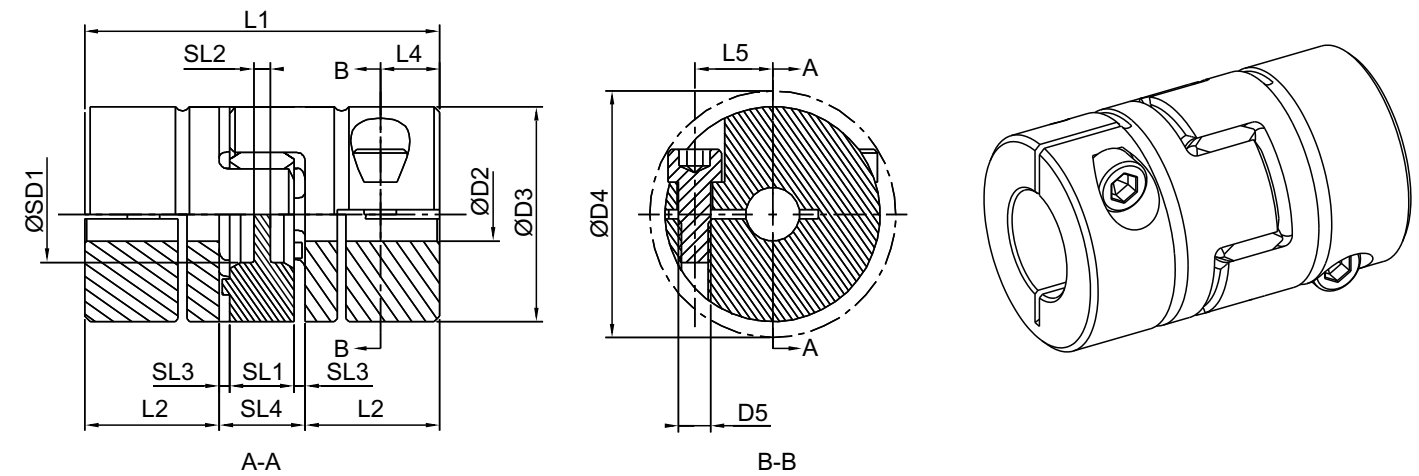

B Type, Size 42-90

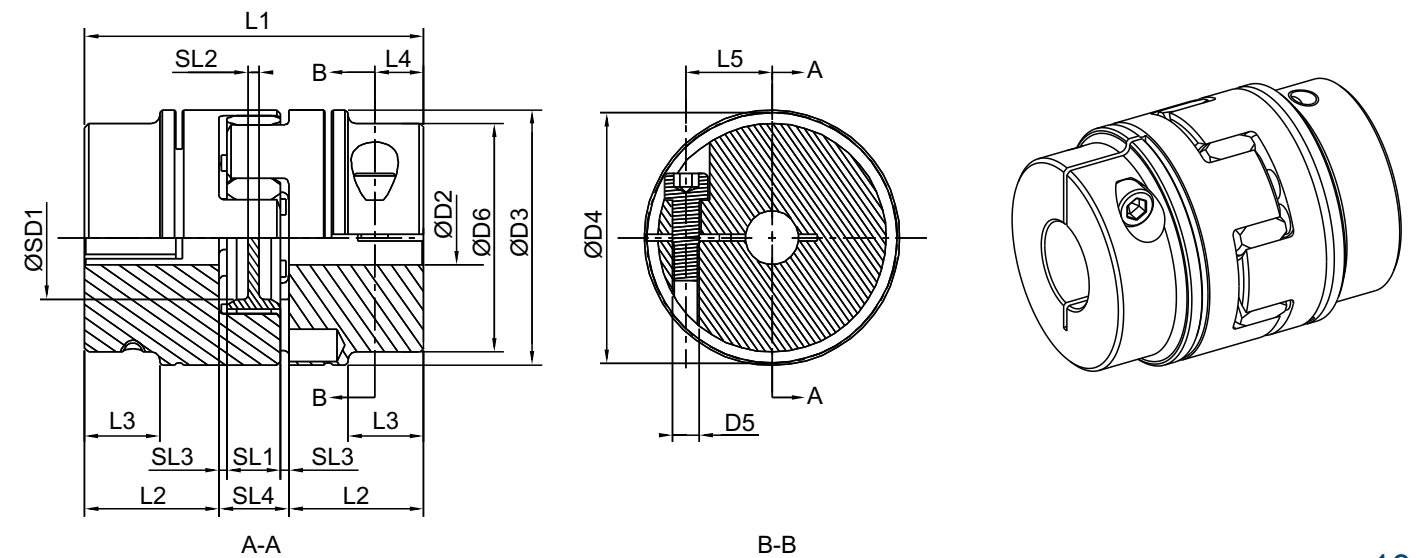

B / BK Type Hub

Spec 07-38 Hub Material - Aluminum.

Spec 42-90 Hub Material - Steel.

Size	Max. Speed [rpm]	D2 max		D3	D6	L1	L2	L3	SD1	SL1	SL2	SL3	SL4	Screw Tightening Torque T_A [Nm]	D4	D5 ⁽²⁾	L4	L5	Inertia ⁽³⁾ J [kg.cm ²]
		B	BK																
07	27000	7	7	14	-	22	7	-	-	6	-	1	8	0.37	16.5	M2	3.5	5	0.001
09	19000	11	11	20	-	30	10	-	7.2	8	1.5	1	10	0.76	23.5	M2.5	5	7.5	0.005
12	15200	12	12	25	-	34	11	-	8.5	10	3.5	1	12	1.34	27.5	M3	5	9	0.015
14	12700	16	16	30	-	35	11	-	8.3	10	2	1.5	13	1.34	32.5	M3	5	11.5	0.028
19	9550	24	24	40	-	66	25	-	18	12	3	2	16	10.5	46	M6	11	14.5	0.193
24	6950	28	28	55	-	78	30	-	27	14	3	2	18	10.5	57.5	M6	10.5	20	0.185
28	5850	38	38	65	-	90	35	-	30	15	4	2.5	20	25	73	M8	11.5	25	0.754
38	4750	45	45	80	-	114	45	-	38	18	4	3	24	25	83.5	M8	15.5	30	1.661
42	4000	50	50	95	85	126	50	28	46	20	4	3	26	69	93.5	M10	18	32	4.866
48	3600	55	55	105	95	140	56	32	48	21	5	3.5	28	120	105	M12	21	36	22.511
55	3150	68	68 ⁽⁴⁾	120	110	160	65	37	60	22	4.5	4	30	120	119.5	M12	26	42.5	38.118
65	2800	70	70 ⁽⁴⁾	135	115	185	75	47	65	26	5.5	4.5	35	120	124	M12	33	45	74.944
75	2350	80	80	160	135	210	85	53	80	30	5	5	40	295	147.5	M16	36	51	121.975
90	1900	90	90	200	160	245	100	62	100	34	9.5	5.5	45	580	176	M20	40	60	266.829

(1) Elastomers with different hardnesses can be found on page 6.

(2) Clamping screws DIN EN ISO 4762.

(3) The moment of inertia of the maximum bore diameter of a single hub.

(4) When the bore diameter $> \varnothing 60$, the position of the keyway will be in the opposite direction to the clamping screw.(5) Finished bore diameter tolerance is H7, bore diameter $> \varnothing 6$ keyway, according to DIN 6885/1, dimensional tolerance is JS9. Please refer to page 6 for keyway dimensions corresponding to each bore diameter.

B Type, Size 19, Bore $\varnothing 22$ - $\varnothing 24$, M4X2 Clamping Screws L5=15 / $T_A=2.9\text{Nm}$

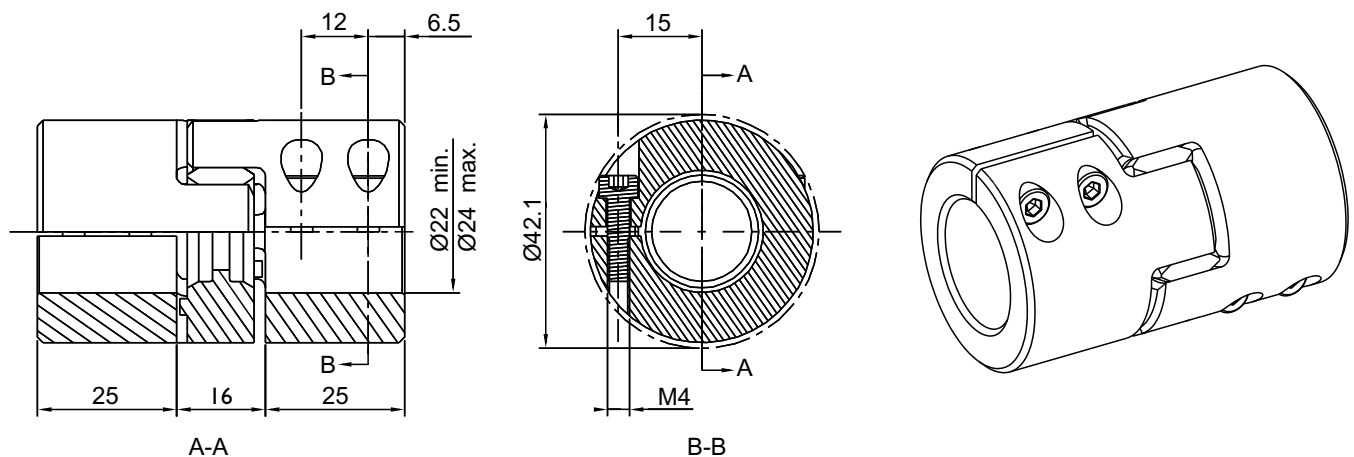

B / BK Type Hub

Bore and Transmittable Torques T _R [Nm]														
Size	Ø3	Ø4	Ø5	Ø6	Ø7	Ø8	Ø9	Ø10	Ø11	Ø12	Ø13	Ø14	Ø15	Ø16
07	0.8	1.0	1.3	1.5	1.8									
09		1.6	2.1	2.5	2.8	3.3	3.7	4.1	4.5					
12		2.4	3.0	3.6	4.2	4.8	5.5	6.0	6.6	7.2				
14			3.0	3.6	4.2	4.8	5.5	6.0	6.6	7.2	7.8	8.5	9.1	9.7

Bore and Transmittable Torques T _R [Nm]																				
Size	Ø8	Ø10	Ø11	Ø14	Ø15	Ø16	Ø18	Ø19	Ø20	Ø22	Ø24	Ø25	Ø28	Ø30	Ø32	Ø35	Ø38	Ø40	Ø42	Ø45
19	19	23	25	31	33	35	38	40	41	43	44									
24		26	28	35	37	39	43	45	46	50	54	55	61							
28				65	69	73	80	84	88	95	102	105	115	122	128	137	146			
38					67	71	79	83	87	94	101	105	115	122	128	138	148	154	160	169

Bore and Transmittable Torques T _R [Nm]																	
Size	Ø18	Ø19	Ø20	Ø22	Ø24	Ø25	Ø28	Ø30	Ø32	Ø35	Ø38	Ø40	Ø42	Ø45	48	50	Ø55
42	188	199	208	225	242	249	274	289	304	326	348	362	374	395	415	428	
48						398	436	416	484	518	552	574	595	625	656	676	723

Bore and Transmittable Torques T _R [Nm]																
Size	Ø32	Ø35	Ø38	Ø40	Ø42	Ø45	Ø48	Ø50	Ø55	Ø60	Ø65	Ø70	Ø75	Ø80	Ø85	Ø90
55	468	504	538	561	583	616	647	668	719	768	816					
65		465	499	521	543	574	606	627	677	727	774	822				
75					1154	1218	1283	1325	1427	1527	1622	1717	1807	1897		
90					1845	1952	2059	2128	2296	2463	2621	2778	2928	3079	3222	3366

C / CK Type Hub

C Type, Size 07-19 (Size 08,13,16 Hollow)

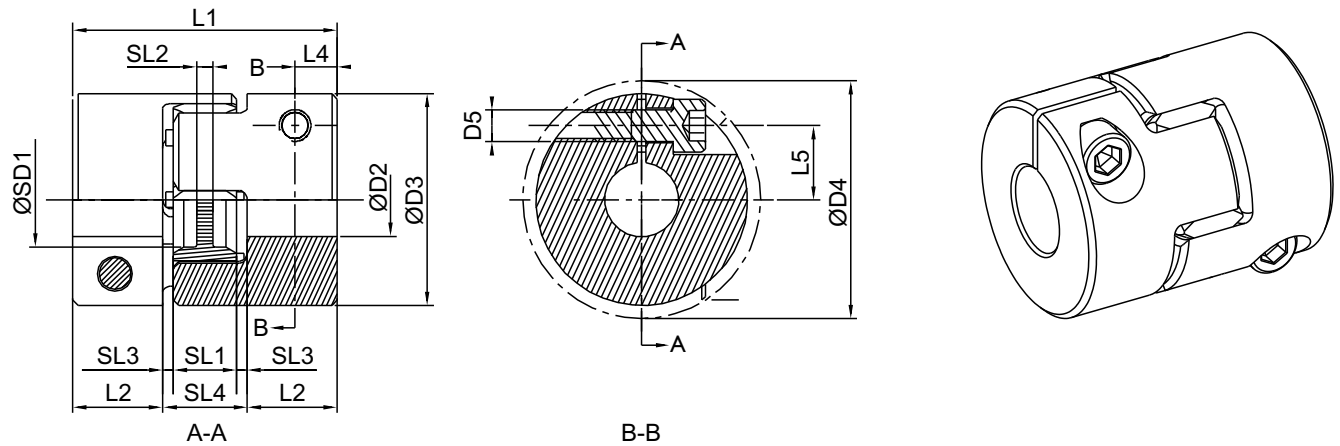

C Type, Size 24-38

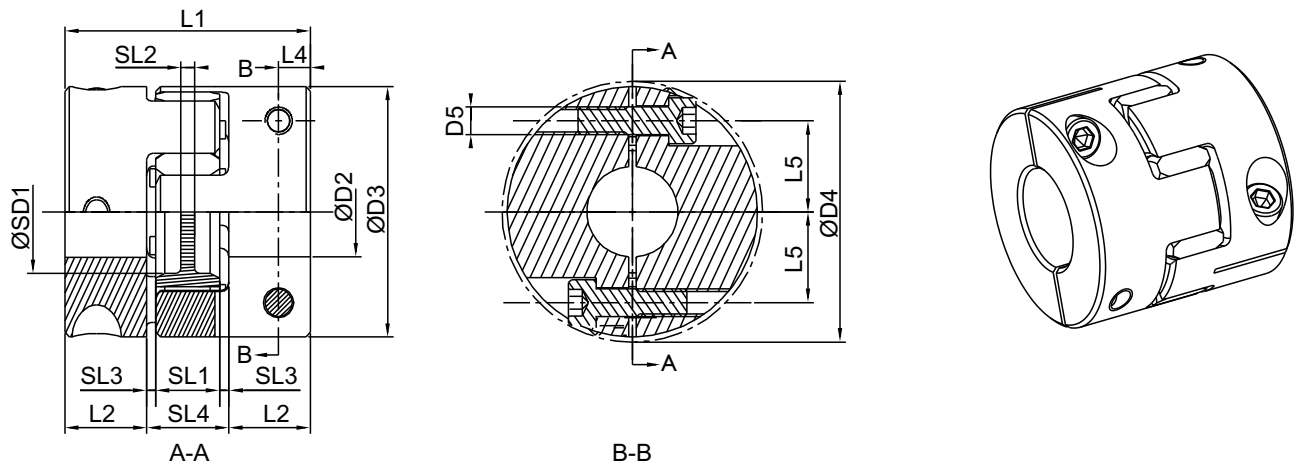

Hub Material - Aluminum.

Size	Max. Speed [rpm]	D2 max	D3	L1	L2	SD1	SL1	SL2	SL3	SL4	Screw Tightening Torque T_A [Nm]	D4	D5 ⁽²⁾	L4	L5	Inertia ⁽³⁾ J [kg.cm ²]
07	27000	7	14	18	5	—	6	—	1	8	0.37	16.5	M2	2.5	5	0.001
08	23800	8	15	20	7	6.2	5	1.5	0.5	6	0.52	17.2	M2	3	5.5	0.001
09	19000	9	20	24	7	7.2	8	1.5	1	10	0.76	21.3	M2.5	3.5	6.7	0.004
12	15200	12	25	26	7	8.5	10	3.5	1	12	1.34	26.2	M3	3.5	8.3	0.011
13	12700	12.7	25	26	8	10	8	1.5	1	10	1.9	25.7	M3	4	8	0.011
14	12700	16	30	32	9.5	8.3	10	2	1.5	13	2.9	31.2	M4	5	10	0.025
16	12000	16	30	32	10.3	14	9.4	2	1	11.4	4.1	32.6	M4	5	10.5	0.027
19	9550	24	40	50	17	18	12	3	2	16	10	45	M6	8	14	0.138
24	10400	32	55	54	18	27	14	3	2	18	10	57.5	M6	7	20	0.491
28	8800	35	65	62	21	30	15	4	2.5	20	25	68.6	M8	9	23.8	1.173
38	7150	45	80	76	26	38	18	4	3	24	49	84.1	M10	11	29.5	3.268

(1) Elastomers with different hardnesses can be found on page 6.

(2) Clamping screws DIN EN ISO 4762.

(3) The moment of inertia of the maximum bore diameter of a single hub.

(4) Finished bore diameter tolerance is H7, hole diameter $>\varnothing 6$ keyway, according to DIN 6885/1, dimensional tolerance is JS9. Please refer to page 6 for keyway dimensions corresponding to each bore diameter.

C / CK Type Hub

C Type, Size 14, Bore $\text{Ø}14\text{-}\text{Ø}16$, M3 Clamping Screws
 $L9=10.4 / D4=30.4 / T_A=1.34\text{Nm}$

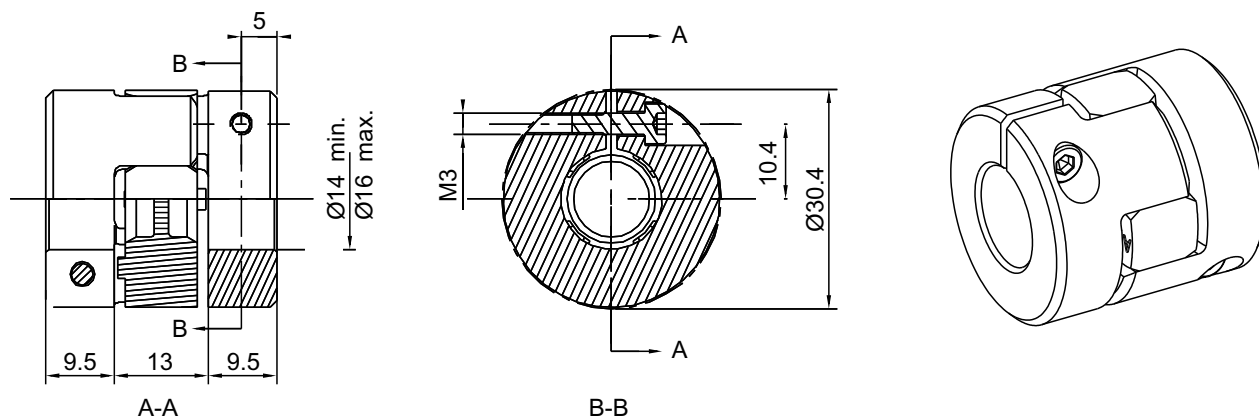

C Type, Size 19, Bore $\text{Ø}21\text{-}\text{Ø}24$, M5 Clamping Screws
 $L9=15.5 / D4=46.8 / T_A=6\text{Nm}$

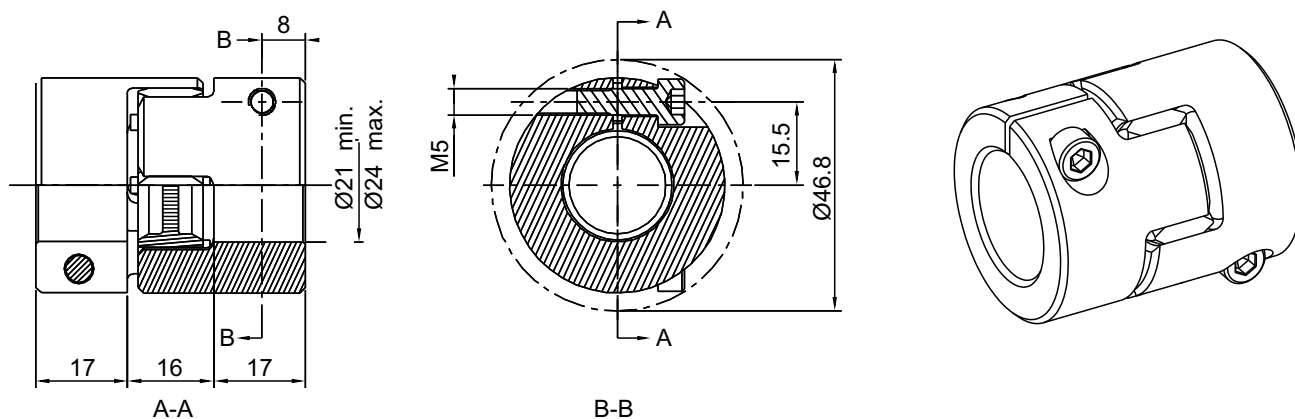

Spec 07-19 Bore and Transmittable Torques T_R [Nm]																	
Size	Ø3	Ø4	Ø5	Ø6	Ø7	Ø8	Ø9	Ø10	Ø11	Ø12	Ø14	Ø15	Ø16	Ø18	Ø19	Ø20	Ø24
07	1.3	1.4	1.5	1.6	1.7												
08	2.0	2.2	2.3	2.5	2.6	2.7											
09		2.8	3.0	3.2	3.3	3.5	3.6										
12		4.8	5.2	5.4	5.6	5.8	6.1	6.3	6.5	6.8							
13		6.4	6.7	7.0	7.3	7.6	7.9	8.2	8.5	8.9							
14			10.2	10.6	11.1	11.5	11.8	12.3	12.7	13.1	8.2	8.5	8.7				
16			14.5	15.1	15.6	16.2	16.8	17.3	17.8	18.4	19.5	20.1	20.6				
19						36.0	36.8	37.8	38.8	39.7	41.7	42.7	43.7	45.7	46.7	47.7	37.2

Spec 24-38 Bore and Transmittable Torques T_R [Nm]																			
Size	Ø10	Ø11	Ø12	Ø14	Ø15	Ø16	Ø18	Ø19	Ø20	Ø24	Ø25	Ø28	Ø30	Ø32	Ø35	Ø38	Ø40	Ø42	Ø45
24	25	28	30	35	38	40	46	48	51	61	63	71	76	81					
28				64	68	73	82	87	91	110	114	128	137	146	160				
38					105	112	126	133	140	167	174	195	209	223	244	265	279	293	314

DL Type Hub

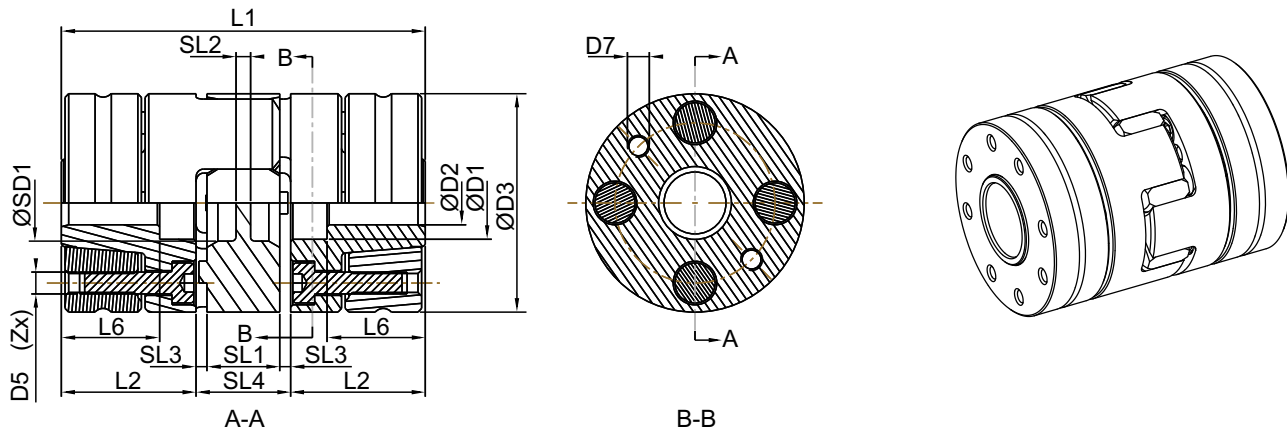

Clamping Ring Hub Material - Aluminum.

Size	Max. Speed [rpm]	D2 max	D3 ⁽⁴⁾	L1	L2	L6	SD1	SL1	SL2	SL3	SL4	Screw Tightening Torque T_A [Nm]	Z	D5 ⁽²⁾	D7 ⁽⁵⁾	Inertia ⁽³⁾ J [kg.cm ²]
14	32000	14	30	50	18.5	13.5	8.3	10	2	1.5	13	1.34	4	M3	M3	0.042
19	24000	20	40	66	25	18	18	12	3	2	16	3	6	M4	M4	0.194
24	17000	32 ⁽⁶⁾	55	78	30	22	27	14	3	2	18	6	4	M5	M5	0.722
28	15000	38	65	90	35	27	30	15	4	2.5	20	6	8	M5	M5	1.663
38	12000	48	80	114	45	35	38	18	4	3	24	10	8	M6	M6	4.837
42	10000	51	95	126	50	35	46	20	4	3	26	25	4	M8	M8	10.891
48	9100	55	105	140	56	41	48	21	5	3.5	28	49	4	M10	M10	18.456

- (1) Elastomers with different hardnesses can be found on page 6.
- (2) Clamping screws DIN EN ISO 4762.
- (3) The moment of inertia of the maximum bore diameter of a single hub.
- (4) Elastomer expansion approx 2mm of ØD3 when applying high speed.
- (5) Remove screw D7 (located between the clamping screws).
- (6) Bore Ø30-Ø32 use M4 clamping screws, Z=8 / $T_A=2.9\text{Nm}$.

DL Type Hub

DL Type Bore and Transmittable Torques T_R [Nm]																								
Size	Tolerance	Ø6	Ø8	Ø9	Ø10	Ø11	Ø14	Ø15	Ø16	Ø19	Ø20	Ø24	Ø25	Ø28	Ø30	Ø32	Ø35	Ø38	Ø40	Ø42	Ø45	Ø48	Ø50	Ø55*
14	H7/k6	9	13	18	19	23	31																	
	H7/h6	7	11	16	16	21	29																	
19	H7/k6				36	44	56	66	51	77	88													
	H7/h6				33	41	51	62	43	70	81													
24	H7/k6						87	102	82	121	137	149	164	214	214	247								
	H7/h6						82	98	73	112	129	138	154	208	205	239								
28	H7/k6								140	205	167	254	279	311	364	340	420	478						
	H7/h6								128	193	147	238	264	293	350	314	400	460						
38	H7/k6										284	430	471	525	613	578	709	722	812	907	914	1059		
	H7/h6										257	405	448	500	592	540	680	682	778	880	876	1031		
42	H7/k6													657	765	724	887	904	1015	978	1143	1321	1354	
	H7/h6													629	741	684	854	861	977	928	1101	1290	1319	
48	H7/k6													814	789	899	1099	1123	1259	1404	1420	1640	1518	1863
	H7/h6													780	746	851	1060	1071	1214	1367	1369	1601	1455	1790

* The standard fit tolerance is H7/k6, when the shaft bore is $\geq \text{Ø}55$ the fit tolerance is G7/m6. If the fit clearance increased, the transmission torque will be reduced. Steel or ductile iron with reduced surface yield strength of more than 250N/mm^2 can be used as the shaft material, the strength and inner diameter of the shaft/hollow shaft need to be checked.

DS Type Hub

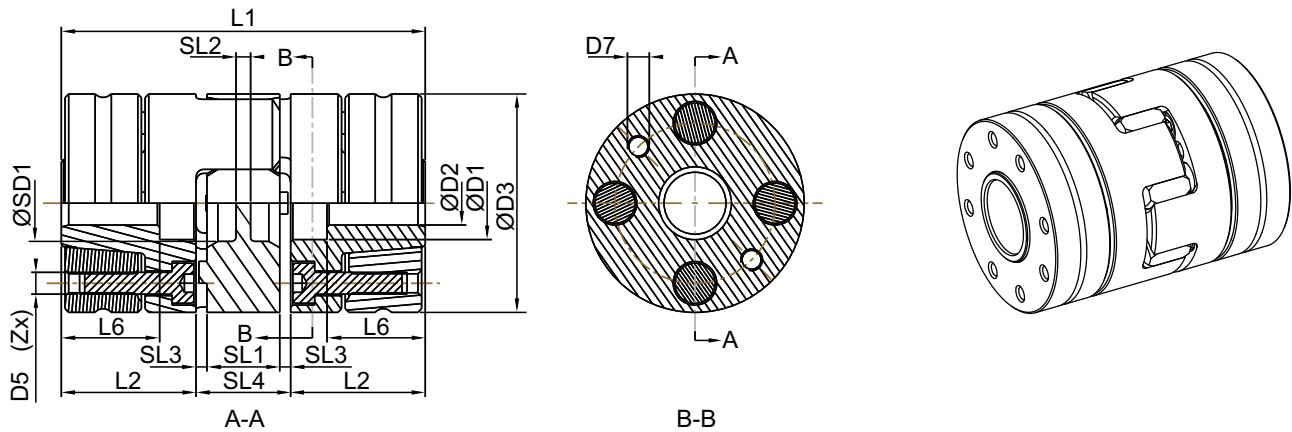

Clamping Ring Hub Material - Steel.

Size	Max. Speed [rpm]	D2 max	D3 ⁽⁴⁾	L1	L2	L6	SD1	SL1	SL2	SL3	SL4	Screw Tightening Torque T_A [Nm]	Z	D5 ⁽²⁾	D7 ⁽⁵⁾	Inertia ⁽³⁾ J [kg.cm ²]
19	19000	20	40	66	25	18	18	12	3	2	16	4.1	6	M4	M4	0.419
24	14000	28	55	78	30	22	27	14	3	2	18	8.5	4	M5	M5	1.802
28	12000	38	65	90	35	27	30	15	4	2.5	20	8.5	8	M5	M5	3.928
38	9600	48	80	114	45	35	38	18	4	3	24	14	8	M6	M6	11.63
42	8050	51	95	126	50	35	46	20	4	3	26	41	4	M8	M8	26.924
48	7200	55	105	140	56	41	48	21	5	3.5	28	69	4	M10	M10	45.212
55	6350	70	120	160	65	45	60	22	4.5	4	30	69	4	M10	M10	86.547
65	5650	70	135	185	75	55	65	26	5.5	4.5	35	120	4	M12	M12	165.679
75	4750	80	160	210	85	63	80	30	5	5	40	120	5	M12	M12	369.565
90	3800	105	200	245	100	75	100	34	9.5	5.5	45	295	5	M16	M16	1049.05

- (1) Elastomers with different hardnesses can be found on page 6.
- (2) Clamping screws DIN EN ISO 4762.
- (3) The moment of inertia of the maximum bore diameter of a single hub.
- (4) Elastomer expansion approx 2mm of ØD3 when applying high speed.
- (5) Remove screw D7 (located between the clamping screws).

DS Type Hub

DS Type 19-42 Bore and Transmittable Torques T_R [Nm]

Size	Tolerance	Ø10	Ø11	Ø14	Ø15	Ø16	Ø19	Ø20	Ø24	Ø25	Ø28	Ø30	Ø32	Ø35	Ø38	Ø40	Ø42	Ø45	Ø48	Ø50
19	H7/k6	28	33	65	78	57	89	103												
	H7/h6	20	24	57	71	45	77	92												
24	H7/k6			66	80	58	91	106	112	125	172									
	H7/h6			57	72	43	77	93	92	107	160									
28	H7/k6				110	130	199	151	245	273	303	361	324	413	475					
	H7/h6				87	107	175	114	214	243	269	334	275	374	441					
38	H7/k6							218	353	393	437	522	469	597	595	683	777	769		
	H7/h6							164	306	349	387	480	396	538	519	617	723	695		
42	H7/k6									445	496	589	533	675	676	773	726	871	1030	1051
	H7/h6									398	443	545	458	614	596	704	633	793	972	985

DS Type 48-90 Bore and Transmittable Torques T_R [Nm]

Size	Tolerance	Ø30	Ø32	Ø35	Ø38	Ø40	Ø42	Ø45	Ø48	Ø50	Ø55*	Ø60*	Ø65*	Ø70*	Ø80*	Ø90*	Ø95*	Ø100*	Ø105*
48	H7/k6	621	709	892	897	1022	967	1153	1356	1221	1526								
	H7/h6	541	620	818	802	939	857	1060	1286	1104	—								
55	H7/k6			849	852	975	918	1101	1103	1227	1277	1625	1592	1953					
	H7/h6			765	745	880	794	996	973	1111	—	—	—	—					
65	H7/k6					1440	1367	1630	1641	1820	1905	2404	2374	2891					
	H7/h6					1309	1200	1485	1466	1662	—	—	—	—					
75	H7/k6						1727	2052	2072	2294	2410	3026	3002	3641	4259				
	H7/h6						1529	1880	1865	2105	—	—	—	—					
90	H7/k6									3848	4269	4810	5835	5910	7029	8050	9200	9539	10753
	H7/h6									3515	—	—	—	—	—	—	—	—	—

* The standard fit tolerance is H7/k6, when the shaft bore is $\geq \text{Ø}55$ the fit tolerance is G7/m6. If the fit clearance increased, the transmission torque will be reduced. The strength and inner diameter of the shaft/hollow shaft need to be checked.

DP Type Hub

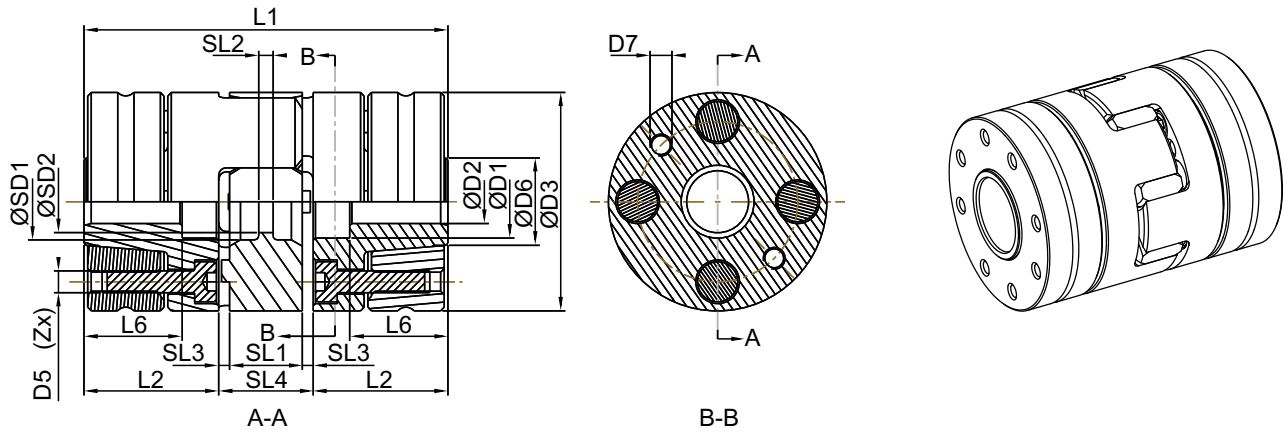

Clamping Ring Hub Material - Steel.

Size	Max. Speed [rpm]	D2 max	D3 ⁽⁴⁾	L1	L2	L6	SD1	SD2	SL1	SL2	SL3	SL4	Screw Tightening Torque T _A [Nm]	Z	D5 ⁽²⁾	D7 ⁽⁵⁾	Inertia ⁽³⁾ J [kg.cm ²]
14	47700	15	32	50	18.5	15.5	8.3	—	10	2	1.5	13	1.89	4	M3	M3	0.123
19	35800	20	40	66	25	21	18	—	12	3	2	16	3.05	6	M4	M4	0.419
24	26000	28	55	78	30	25	27	—	14	3	2	18	8.5	4	M5	M5	1.8
28	22000	38	65	90	35	30	30	—	15	4	2.5	20	8.5	8	M5	M5	3.916
38	17900	48	80	114	45	40	38	—	18	4	3	24	14	8	M6	M6	11.646
42	15000	51	95	126	50	45	46	18.5	20	4	3	26	35	4	M8	M8	26.963
48	13600	55	105	140	56	50	48	20.5	21	5	3.5	28	69	4	M10	M10	45.256
55	11900	70	120	160	65	58	60	22.5	22	4.5	4	30	69	4	M10	M10	86.677
65	11000	70	135	185	75	55	65	30	26	5.5	4.5	35	120	4	M12	M12	165.68
75	8950	80	160	210	85	63	80	40	30	5	5	40	120	5	M12	M12	369.566
90	7150	105	200	245	100	75	100	50	34	9.5	5.5	45	295	5	M16	M16	1049.05

- (1) Elastomers with different hardnesses can be found on page 6.
- (2) Clamping screws DIN EN ISO 4762.
- (3) The moment of inertia of the maximum bore diameter of a single hub.
- (4) Elastomer expansion approx 2mm of ØD3 when applying high speed.
- (5) Remove screw D7 (located between the clamping screws).

DP Type Hub

DP Type 14-42 Bore and Transmittable Torques T_R [Nm]																			
Size	Tolerance	Ø10	Ø11	Ø14	Ø15	Ø16	Ø19	Ø20	Ø24	Ø25	Ø28	Ø30	Ø32	Ø35	Ø38	Ø40	Ø42	Ø45	Ø50
14	H6/k6	11	13	29	35														
	H6/h6	3	3	21	28														
19	H6/k6	34	41	76	91	69	106	120											
	H6/h6	22	27	64	81	50	87	104											
24	H6/k6			79	94	71	110	126	134	150	202								
	H6/h6			64	81	47	85	104	102	120	183								
28	H6/k6				127	149	224	176	276	305	339	401	365	458	525				
	H6/h6				94	116	189	123	231	263	292	362	295	403	476				
38	H6/k6							249	389	429	478	564	516	646	651	740	835	833	
	H6/h6							177	326	371	412	509	420	569	549	652	764	734	
42	H6/k6								390	435	514	467	588	590	673	635	758	892	911
	H6/h6								331	368	458	371	510	489	584	517	659	818	828

DP Type 48-90 Bore and Transmittable Torques T_R [Nm]																			
Size	Tolerance	Ø30	Ø32	Ø35	Ø38	Ø40	Ø42	Ø45	Ø48	Ø50	Ø55*	Ø60*	Ø65*	Ø70*	Ø80*	Ø90*	Ø95*	Ø100*	Ø105*
48	H6/k6	672	762	944	957	1082	1034	1220	1423	1298	1607								
	H6/h6	570	649	852	837	978	895	1103	1334	1151	-								
55	H6/k6			920	931	1057	1006	1193	1202	1329	1394	1747	1729	2094					
	H6/h6			808	787	930	840	1052	1029	1174	-	-	-	-					
65	H6/k6					1533	1469	1734	1755	1936	2042	2540	2531	3047					
	H6/h6					1362	1251	1545	1527	1729	-	-	-	-					
75	H6/k6						1862	2192	2225	2449	2593	3210	3212	3851	4496				
	H6/h6						1610	1971	1960	2208	-	-	-	-	-				
90	H6/k6									4027	4486	5039	6053	6164	7306	8381	9507	9871	11056
	H6/h6									3633	-	-	-	-	-	-	-	-	-

*When the shaft bore is $\geq \text{Ø}55$ the fit tolerance is G6/m6. If the fit clearance increased, the transmission torque will be reduced. For calculation of the decompression strength of the shaft/hollow shaft, see the installation instructions.

DP Type Hub

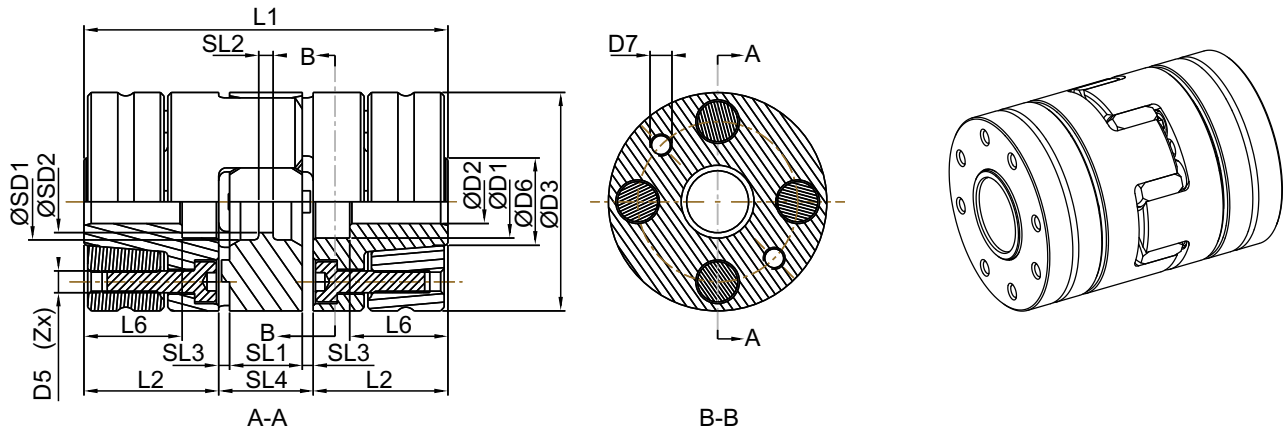

Selection according to spindle specifications

Spindle Spec	Size	Dimensions according to DIN 69002																		
		D2 ⁽¹⁾	D1	D3 ⁽⁶⁾	D6	L1	L2	L6	SD1	SD2	SL1	SL2	SL3	SL4	T _A [Nm]	Z	D5 ⁽⁴⁾	D7 ⁽⁷⁾	T _R [Nm]	J ⁽⁵⁾ [kg.cm ²]
25 x 20 ⁽²⁾	14P	14	17	32	17	50	18.5	15.5	8.3	6	10	2	1.5	13	1.89	4	M3	M3	25	0.125
32 x 25	19P37.5	16	19	37.5	20	66	25	21	18	9.5	12	3	2	16	3.05	6	M4	M4	60	0.325
32 x 30	19P	19	22	40	23	66	25	21	18	9.5	12	3	2	16	3.05	6	M4	M4	71	0.423
40 x 35	24P50	24	29	50	28	78	30	25	27	12.5	14	3	2	18	8.5	4	M5	M5	108	1.209
50 x 45	24P	25	30	55	30	78	30	25	27	12.5	14	3	2	18	8.5	4	M5	M5	170	1.84
63 x 55	28P	35	40	65	40	90	35	30	30	14.5	15	4	2.5	20	8.5	8	M5	M5	506	4.023
80 x 75 ⁽²⁾	38P	40	46	80	46	114	45	40	38	16.5	18	4	3	24	14	8	M6	M6	821	12.397

(1) Standard spindle diameter.

(2) Not according to DIN 69002.

(3) Elastomers with different hardnesses can be found on page 6.

(4) Clamping screws DIN EN ISO 4762.

(5) The moment of inertia of the maximum bore diameter of a single hub.

(6) Elastomer expansion approx 2mm of ØD3 when applying high speed.

(7) Remove screw D7 (located between the clamping screws).

E / EK Type Hub

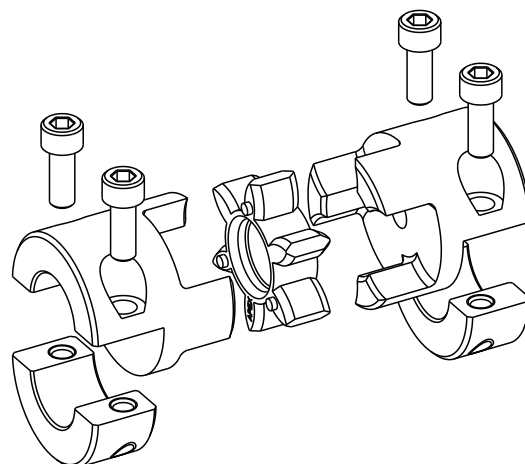
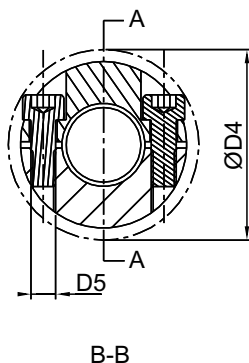
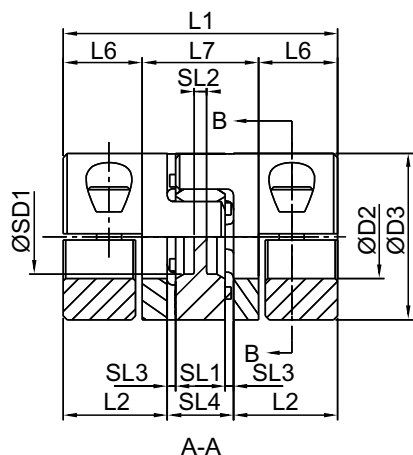

With maximum bore the feather keyways are offset to each other by approx 5°, Material - Aluminium.

Size	Max. Speed [rpm]	D2 max	D3	L1	L2	L6	L7	SD1	SL1	SL2	SL3	SL4	Screw Tightening Torque T_A [Nm]	D4	D5 ⁽²⁾	Inertia ⁽³⁾ J [kg.cm ²]
19	9550	20	40	66	25	19	28	18	12	3	2	16	10	46	M6	0.199
24	6950	30	55	78	30	22	34	27	14	3	2	18	10	57.5	M6	0.763
28	5850	38	65	90	35	25	40	30	15	4	2.5	20	25	73	M8	1.719
38	4750	45	80	114	45	33	48	38	18	4	3	24	25	83.5	M8	5.035
42	4000	50	95	126	50	36.5	53	46	20	4	3	26	49	93.5	M10	11.344

- (1) Elastomers with different hardnesses can be found on page 6.
- (2) Connecting screws DIN EN ISO 4762.
- (3) The moment of inertia of the maximum bore diameter of a single hub.
- (4) Finished bore diameter tolerance is H7, hole diameter >Ø6 keyway, according to DIN 6885/1, dimensional tolerance is JS9. Please refer to page 6 for keyway dimensions corresponding to each bore diameter.

Bore and Transmittable Torques T_R [Nm]																								
Size	Ø8	Ø10	Ø11	Ø14	Ø15	Ø16	Ø18	Ø19	Ø20	Ø22	Ø24	Ø25	Ø28	Ø30	Ø32	Ø35	Ø38	Ø40	Ø42	Ø45	Ø46	Ø48	Ø50	
19	20	25	28	35	38	40	46	48	51															
24		25	28	35	38	40	46	48	51	56	61	63	71											
28				64	68	73	82	87	91	100	110	114	128	137	146	160	173							
38							82	87	91	100	110	114	128	137	146	160	173	183	192	205				
42										154	167	174	195	209	223	244	265	279	293	314	321	335	349	

F Type Hub

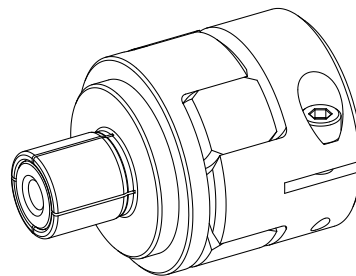
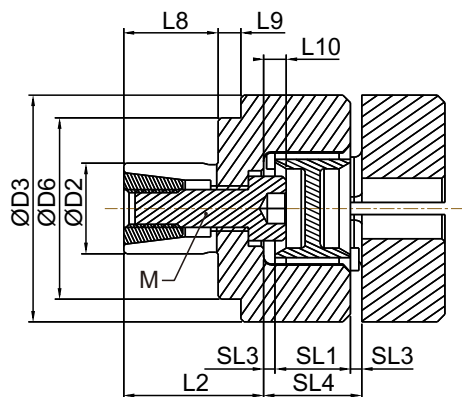

Hub Material - Aluminum.

Size	D2	D3	D6	L2	L8	L9	L10	SL1	SL3	SL4	M ⁽⁵⁾	Screws Tightening Torque T _A [Nm]	Inertia ⁽³⁾ J [kg.cm ²]	Transmittable Torques T _R [Nm] ⁽⁴⁾
09	10	20	–	20	12	–	0	8	1	10	M4	4	0.005	6.4
12	10	25	20	19	14	1.5	2	10	1	12	M4	4	0.009	7.7
14	12	30	24	18.5	12.5	3	2	10	1.5	13	M5	8	0.016	7.7
19	20	40	35	28	20	1	0	12	2	16	M6	14	0.093	35.7
24	25	55	45	38	30	1	4	14	2	18	M8	38	0.314	82
28	35	65	55	44	36	1	5	15	2.5	20	M10	65	0.741	182

(1) Elastomers with different hardnesses can be found on page 6.

(2) Expandable hub can be connected to other types of hubs. Please refer to the pages of each type for hub dimensions.

(3) The moment of inertia of the maximum bore diameter of a single hub.

(4) The transmittable torque can be specified according to the drawing D2, L2, L8 and L9.

(5) Connecting screws DIN EN ISO 4762.

G Type Hub

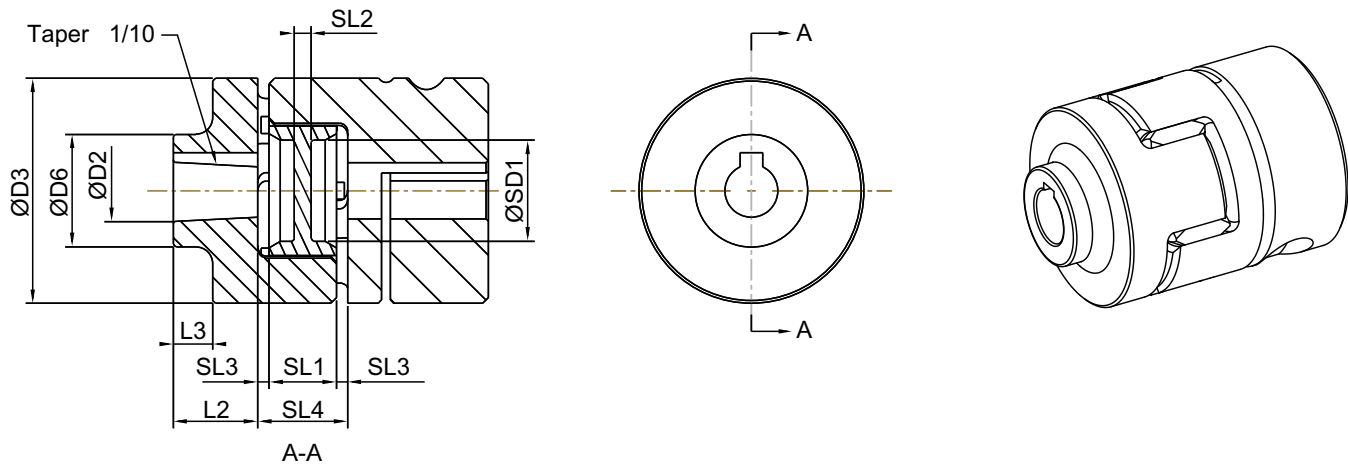

Hub Material - Steel.

Size	D2	D3	D6	L2	L3	SD1	SL1	SL2	SL3	SL4	Inertia ⁽²⁾ J [kg.cm ²]
19	11	40	20	15	7	18	12	3	2	16	0.228
19	14	40	20	18	10	18	12	3	2	16	0.241
24	16	55	28	28	16	27	14	3	2	18	1.098
38	32	80	50	58	42	38	18	4	3	24	7.754
42	38	95	60	58	38	46	20	4	3	26	17.776

(1) Elastomers with different hardnesses can be found on page 6.

(2) The moment of inertia of the maximum bore diameter of a single hub.

N Type Hub

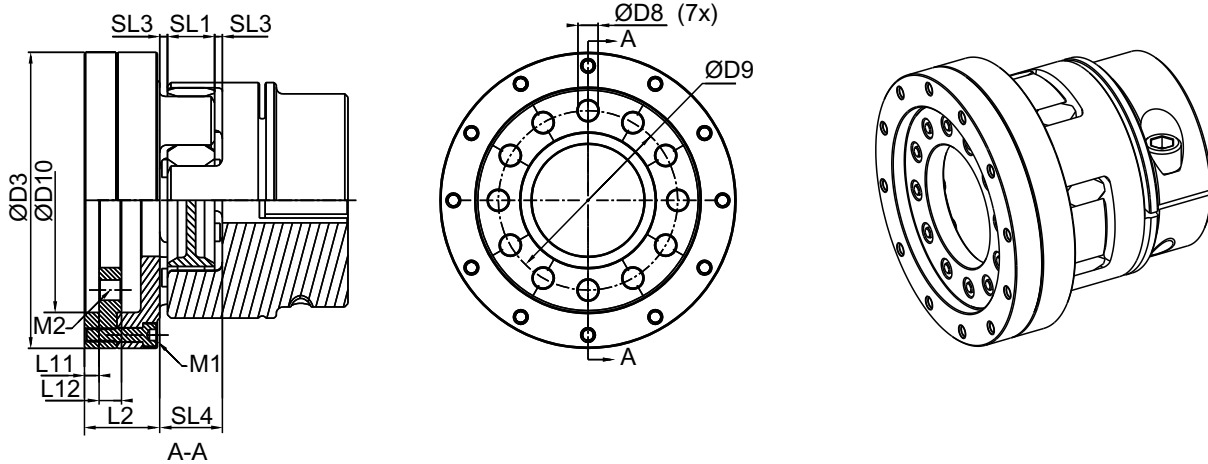

Spec 19-38 Hub Material - Aluminum.

Spec 48-90 Hub Material - Steel.

Size	D3	D8	D9	D10	L2	L11	L12	SL1	SL3	SL4	Applicable Models	M1 ⁽³⁾	T _A [Nm]	M2 ⁽⁴⁾	T _A [Nm]	Inertia ⁽²⁾ J[kg.cm ²]
19	63.5	5.5	31.5	40	22.5	3	6	12	2	16	AH064	M4	4.9	M5	8.2	1.41
28	86.5	6.6	50	63	31.5	5.5	7	15	2.5	20	AH090	M5	9.8	M6	14	7.1
38	108	6.6	63	80	36.5	6	6.5	18	3	24	AH110	M6	17	M6	14	17.96
48	132	9	80	100	37.5	6.5	10	21	3.5	28	AH140	M6	17	M8	34	74.12
65	188	11	125	160	42.5	7.5	10	26	4.5	35	AH200	M8	41	M10	67	333.61
75	244	18	140	180	60	8	16	30	5	40	AH255/ AP255	M12	139	M16 ⁽³⁾	343	1396.28
90	280	22	160	200	75.5	8	20	34	5.5	45	AH285	M12	139	M20 ⁽³⁾	660	3113.59
28	86.5	6.6	50	63	31.5	5.5	7	15	2.5	20	AP090	M6	17	M6	14	7.52
38	108	9	63	80	36.5	6	6.5	18	3	24	AP110	M6	17	M8	34	18.7
48	132	9	80	100	37.5	6.5	10	21	3.5	28	AP140	M6	17	M8 ⁽³⁾	34	74.08
65	188	11	125	160	42.5	7.5	10	26	4.5	35	AP200	M8	41	M10	67	332.44
90	280	26	160	200	75.5	8	20	34	5.5	45	AP285	M12	139	M24 ⁽³⁾	1140	3205.38

(1) Elastomers with different hardnesses can be found on page 6.

(2) The moment of inertia of the maximum bore diameter of a single hub.

(3) Connecting screws ISO 4762.

(4) Connecting screws ISO 4017.

Order example : E-19-A-NH064-0

Q Type Double-Cardanic

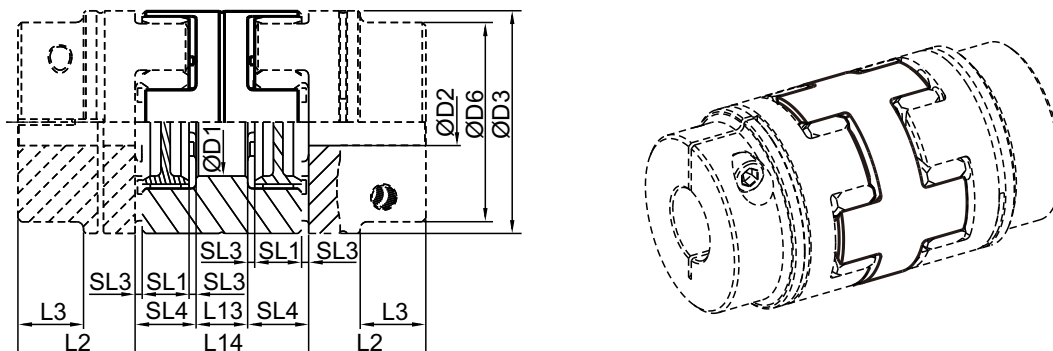

Hub Material - Aluminum.

Size	Max. Speed [rpm]	D1	L13	L14	SL1	SL3	SL4	Inertia ⁽³⁾ J [kg.cm ²]
07	40900	4	4	20	6	1	8	0.001
09	28600	6	5	25	8	1	10	0.004
12	22900	8	6	30	10	1	12	0.014
14	19100	10	8	34	10	1.5	13	0.028
19	14300	15	10	42	12	2	16	0.125
24	10400	24	16	52	14	2	18	0.556
28	8800	30	18	58	15	2.5	20	1.198
38	7150	38	20	68	18	3	24	3.137
42	6000	46	22	74	20	3	26	6.842
48	5450	51	24	80	21	3.5	28	10.985
55	4750	60	28	88	22	4	30	21.196

(1) Elastomers with different hardnesses can be found on page 6.

(2) Can be connected to other types of hubs. Please refer to the pages of each type for hub dimensions.

(3) Moment of inertia of the connecting ring.

COUPLING SELECTION ACCORDING TO DIN 740 PART II WITH SPECIFIC FACTORS

Glossary

Rated torque of coupling T_{KN}	Nm	Torque to be continuously transmitted over the entire permissible speed range, taking into account the factors.
Friction torque T_R	Nm	The torque transmitted when the shaft is securely connected to the sleeve.
Rated torque of driving side T_{AN}	Nm	Constant driving torque from the motor.
Peak torque of machine T_S	Nm	Peak torque on the coupling.
Peak torque of driving side T_{AS}	Nm	The peak torque generated when the motor starts or stops.
Mass moment inertia of driving side J_A	kgm ²	Total of moments of inertia existing on the driving side referring to the coupling speed
Mass moment inertia of load side J_L	kgm ²	Total of moments of inertia existing on the load side referring to the coupling speed.
Rotational inertia coefficient of driving side M_A		Factor considering the mass distribution with shocks and vibrations generated on the driving or load side.
Temperature factor S_t		Temperature requirements for the couplings.
Operating factor S_b		Factor for different application.
Starting factor S_z		The number of start-ups per hour.

COUPLING SELECTION ACCORDING TO DIN 740 PART II WITH SPECIFIC FACTORS

Coefficient / Factor

Temperature factor S_t										
Hardness	-50°C ~ +30°C	≤40°C	≤50°C	≤60°C	≤70°C	≤80°C	≤90°C	≤100°C	≤110°C	≤120°C
TPU 64 Sh-D ⁽¹⁾	1	1.2	1.3	1.4	1.55	1.8	2.2	3	3	3
TPU 98 Sh-A ⁽¹⁾	1	1.2	1.3	1.4	1.55	1.8	2.2	3	-	-
TPU 80 Sh-A ⁽¹⁾	1	1.2	1.3	1.4	1.55	1.8	2.2	3	-	-
TPU 65 Sh-D ⁽²⁾	1	1.2	1.3	1.4	1.55	-	-	-	-	-
Hytrel 64 Sh-D	1	1.2	1.3	1.4	1.5	1.6	1.8	2	2.3	2.8

(1) Temperature support reaches -30°C.

(2) Temperature support reaches -10°C.(Conductive)

Operating factor S_b		
Backlash-free drives		
Main spindle drive of machine tools		2~5
Moderate shocks	Grinders, small milling	1.5~2.5
Average shocks	Milling machines/drills with interrupted	2~3
Heavy shocks	Milling machines etc.	2.5~3.5
Ball screw drive / toothed belt drive		2.5~4
Gearbox Ratio (i)	3~≤5	8
	<5~≤7	5
	7<	3
Servo-hydraulic drives		
With pulsating load ⁽¹⁾		1.2~1.3
With alternating load ⁽²⁾		1.3~1.5

*When using the elastomer 64 Sh-D or 65 Sh-D a minimum factor of 4.

(1) With dynamic load the use of aluminium is permissible.

(2) With vibratory load please make use of steel hubs.

(Shaft encoder drives: Subject to the low torques to be transmitted the coupling size for shaft encoder drives is selected according to the shaft diameters to be connected.)

Starting Factor S_z	
Starting Frequency / Hour	
< 20	1.0
< 60	1.2
< 120	1.4
< 180	1.6
< 240	1.8
≥ 240	2.0

COUPLING SELECTION ACCORDING TO DIN 740 PART II WITH SPECIFIC FACTORS

Calculation

The rated torque T_{KN} of the coupling must be greater than or equal to the rated torque of the equipment T_{AN} , taking into account the temperature coefficient S_t and the operating coefficient S_B .

$$T_{KN} \geq T_{AN} \times S_t \times S_B$$

The rated torque T_{KN} of the coupling must be greater than or equal to the maximum torque T_s applied to the coupling, taking into account the temperature coefficient S_t and the operating coefficient S_B .

$$T_{KN} \geq T_s \times S_t \times S_B$$

Rotational inertia coefficient at the drive side M_A

$$M_A = J_L / (J_A + J_L)$$

Maximum torque at the drive side T_s

$$T_s = T_{AS} \times M_A \times S_Z$$

Under any operation conditions, the friction torque on the coupling bore may not be exceeded.

$$T_R > T_{AS}$$

Note



**APEX TAIWAN NORTH
ANDTEK AUTOMATION CO.,LTD**
TEL +886-02-82262655
13F-5, NO.2, Jian 8th Rd., Jhonghe Dist., New
Taipei City 235, TAIWAN
sales@andtek.com.tw
www.apexdyan.com



**APEX TAIWAN CENTRAL
ANDTEK AUTOMATION CO.,LTD**
TEL +886-04-23594286
9F-6, NO.925, Sec.4, Taiwan Blvd., Xitun Dist.
Taichung City 407, TAIWAN
sales@andtek.com.tw
www.apexdyan.com



**APEX TAIWAN SOUTH
MEN JENN ELECTRIC CO., LTD.**
TEL +886-06-2337332~6
NO.774, Zhonghua Rd., Yongkang Dist., Tainan
City 710, TAIWAN
menjenn@ms74.hinet.net
www.apexdyan.com



APEX TAIWAN INC. SHANGHAI
TEL +86-21-69220577
NO.128 ZHUYING Road QINGPU Industry Area,
Shanghai, CHINA
sales@apexdyan.cn
www.apexdyan.com



APEX DYNAMICS SHENZHEN, LTD.
TEL +86-755-84516325
NO. 1102A of D area, CFG mansion, Bao Yuan
Road, Bao'an District, Shenzhen, CHINA.
sales@szapexdyan.com
www.szapexdyan.com



APEX DYNAMICS BEIJING, LTD.
TEL +86-10-69570691
NO. 1, Yao Ping Road, Song Zhuang Town, Tongzhou
District, Beijing, CHINA.
bjapexdyan@163.com
www.bjapex.cn



CHONGQING APEX DYNAMICS CO., LTD.
TEL +86-23-67688860
406, Building 5, NO. 68, Jinyu Avenue, Beibu New
Area, Chongqing, CHINA
sales@cqapexdyan.com
www.apexdyan.com



APEX (XIAMEN) DYNAMICS TECHNOLOGY CO., LTD.
TEL +65-0592-720-5279
Unit B-3, 1F., NO. 129, Jingquan Road, Jimei District,
Xiamen, Fujian, CHINA
sales@xmapexdyan.com
www.xmapexdyan.com



APEX DYNAMICS USA, INC.
TEL +1-631-2449040
885 Marconi Avenue Ronkonkoma, NY 11779
U.S.A.
sales@apexdynamicsusa.com
www.apexdynamicsusa.com



APEX DYNAMICS KOREA INC
TEL +82-31-8179992
7-5, Aenigol-gil, Ilsandong-gu, Goyang-si, Gyeonggi-do,
Republic of Korea 10301
sales@apexdynakorea.co.kr
www.apexdynakorea.co.kr



APEX DYNAMICS JAPAN
TEL +88-092-4511202
1-3-46, Hannichibasi, Hakata-ku, Fukuoka,
812-0897, JAPAN
sales@apexdyan.jp
www.apexdyan.jp



APEX DYNAMICS SINGAPORE PTE LTD
TEL +34-93-6562228
3 South Buona Vista Road, #05-15 & #06-15.
SINGAPORE 118136
sales@apexdyan.com.sg
www.apexdyan.com.sg



APEX DYNAMICS (THAILAND) CO., LTD.
TEL +66-2-326623
87 Soi Ladkrabang 30, Ladkrabang, Ladkrabang,
Bangkok 10520, Thailand
Apexthai2010@gmail.com
www.apexdyan.co.th



APEX DYNAMICS BV
TEL +31-492-509995
Churchillaan 101 5705 BK Helmond, NETHERLANDS
sales@apexdyan.nl
www.apexdyan.nl
www.apexdyan.be



**APEX DYNAMICS
POLSKA SP. Z O.O.**
TEL +48-12-6304728
Ul. Krakowska 50, 32-083 Balice, Poland
sales@apexdyan.pl
www.apexdyan.pl



APEX DYNAMICS SPAIN, S.L.
TEL +34-93-6562990
Carrereta Laureà Miró, 407
08980 - Sant Feliu de Llobregat, Barcelona, SPAIN
sales@apexdyan.es
www.apexdyan.es



Big Diamond Trading Company LLC
TEL +968-94268885
2nd floor, Regus, Tamimah building, Al
Wattayah, Muscat, Oman
ar.gorji@diamondtradings.com



APEKS DINAMIK REDUKTOR DISLI SAN TIC AS
TEL +90-232-4589960
10053 SOKAK NO: 9 A.O.S.B. CIGLI-IZMIR -TURKEY
sales@apexdyan.com.tr
www.apexdyan.com.tr



APEX DYNAMICS AUSTRALIA PTY LTD.
TEL +613-95-852739
36 Taunton Drive,Cheltenham, Victoria 3192
AUSTRALIA.
sales@apexdyan.com.au
www.apexdyan.com.au



APEX DYNAMICS (I) JV
TEL +91-9607927142
Shop No. 02, S. No. 100/5, Pune-Satara Highway,
Ambegaon Khurd, Pune-411046 Maharashtra, India
sales@apexdyan.co.in
www.apexdyan.co.in



APEX DYNAMICS FRANCE SAS
TEL +33-160-135097
11 - Burospace - 91570 - Bièvres, France
info@apexdyan.fr
www.apexdyan.fr



APEX DYNAMICS SWEDEN AB
TEL +46-75-242444
Fredrikbergsgatan 2 SE-573 92 Tranås, SWEDEN
sales@apexdyan.se
www.apexdyan.se



PT.APEX DYNAMICS INDONESIA
TEL +62 21 2928 3681
Rukan Aralia Blok HY43 no.11,Harapan Indah II,
Bekasi - Jawa Barat, INDONESIA 17214
sales@apexdyan.co.id
www.apexdyan.co.id



APEX DYNAMICS GERMANY GMBH
TEL +49-7171 798069-0
Marie-Curie-Straße 25 D-73529 Schwäbisch Gmünd
werner.langer@apexdynamics.de
www.apexdynamics.de



APEX DYNAMICS CZECH S.R.O.
TEL +420-577-663877
tř. Tomáše Bati 1851 765 02 Otrokovice Česká
REPUBLIKA
info@apexdynaczech.cz
www.apexdynaczech.cz



APEX DYNAMICS РОССИЯ
TEL +7-495-2255452
TEL +7-495-6462422
г.Москва,ул. Южнопортовая, дом 7, строение
"С", 3-й этаж
info@apexdynarussia.ru
www.apexdynarussia.ru



APEX DYNAMICS MIDLANDS LTD
TEL +44-0121-737-1170
Heath House, Cheadle Rd, Uttoxeter,
ST14 7BY, UK
mikeg@apexdynauk.com
www.apexdynauk.com



APEX DYNAMICS SWITZERLAND AG
TEL +41-55-4517020
Obergasse 40, CH-8854 Galgenen, Switzerland
info@apexdyan.ch
www.apexdyan.ch



APEX DYNAMICS MOTION (M) SDN BHD
TEL +60 7267 4228
Block A1-2, #35-03, Mercu 1 Jalan Tanjung Puteri 1,
R & F Tanjung Puteri, Johor Bahru 80300, Johor.
sales@apexdyan.com.sg
www.apexdyan.com.sg



APEX DYNAMICS BRAZIL
TEL +55-47-30298700
Rua Senador Petrônio Portela, 47-Bloco 5, Zona
Industrial Norte-CEP 89218-575-Joinville (SC)
lucao@neoyama.com.br
adriano.duarte@neoyama.com.br
www.neoyama.com.br



APEX DYNAMICS ITALY SRL
TEL +39 02 36634521
VIA E. DE AMICIS, 2-20091 BRESSO (MI)
info@apexdynamics.it
www.apexdynamics.it



APEX DYNAMICS AUSTRIA GmbH
TEL +43 720788416
Dr. Hans-Lechner-Strasse 6,
5071 Wals-Siezenheim
info@apexdynamics.at
www.apexdynamics.at



UAB "APEKSO DINAMIKA"
TEL +370 52078165
Medaus g. 28A,
Medininku k., Vilniaus r. Sav.
LT-13192
info@apexdyan.lt
www.apexdyan.lt



APEX DYNAMICS DENMARK
TEL +45 73121260
Grundtvigs Allé 165, 6400
Sønderborg, Denmark
sales@apexdyan.dk
www.apexdyan.dk



APEX DYNAMICS ISRAEL
TEL +972-3-6470471
17 Hamefalsim St., Kiryat Arye,
Petach-Tikva 4951447
Sales@apexdynamics.co.il
www.apexdynamics.co.il



APEX DYNAMICS SLOVAKIA S.R.O.
TEL +421919400476
Trenčianska cesta 887/52, 957 01
Bánovce nad Bebravou, Slovak republic
office@apexdyan.sk
www.apexdyan.sk



APEX DYNAMICS, INC.

No10. Keyuan 3rd RD.Situn District, Taichung City 40763, Taiwan (R.O.C)
Tel:886-4-24650219 | Fax:886-4-24650118
sales@apexdyan.com | <http://www.apexdyan.com>

APEX-2024-08-Elastomer Coupling-TWN

Printed in Taiwan



APEX DYNAMICS VIETNAM TRADING SERVICES CO., LTD
TEL +84-028-35350628
267 Duong so 7, P. Binh Tri Dong B, Q. Binh Tan,
Thanh pho Ho Chi Minh,Vietnam
Sales@apexdyan.vn
www.apexdyan.vn

