



APEX DYNAMICS, INC.

High Performance Gearbox

MGO / MGOK Series

MGOH / MGOHK

MGOHC / MGOHCK Series

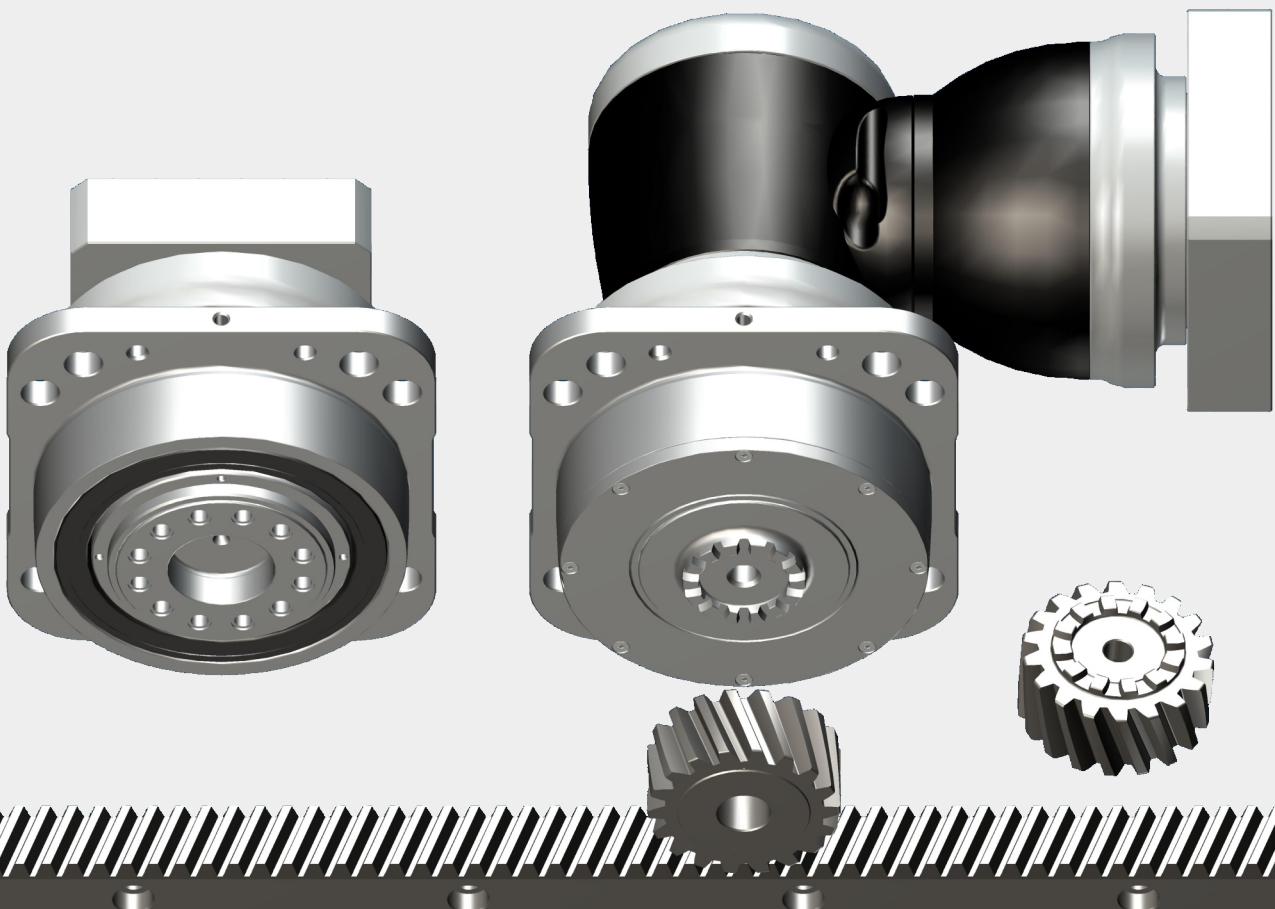

Gearbox Series - MGO / MGOK

► Features:

- Enhanced Axial and Radial Load
- Enlarged Holes on Flange for Easy Installation and Adjustment
- High Torque
- High Torsional Rigidity
- High Precision
- Long-Term Persistence of Low Backlash
- Long Service Life
- High Efficiency / Optimized Inertia Moment
- Identical Input-Output Rotating Direction with Hypoid Right-Angle K-Series



Ordering Code - MGO / MGOK Series

MGO115	—	005		/	MOTOR
MGOK115	—	012	—	A	/ MOTOR
MGOKB115					Motor Type
					Application Direction
					Ratio
					Gearbox Size

Gearbox Size
MGO 115 / 140 / 170 / 240 / 285 / 320
MGOK 115 / 140 / 170 / 240 / 285 / 320

Ratio⁽¹⁾
MGO (1 Stg.) 4 / 5 / 7 / 10
(2 Stg.) 16 / 20 / 21 / 25 / 28 / 31 / 35 / 40 / 46 / 50 / 61 / 70 / 91 / 100
MGOK (2 Stg.) 12 / 15 / 16 / 20 / 25 / 28 / 35 / 40 / 49 / 50 / 70 / 100
MGOKA (3 Stg.) 100 / 125 / 140 / 175 / 200 / 250 / 350 / 500 / 700 / 1,000
MGOKB (3 Stg.) 64 / 84 / 100 / 125 / 140 / 175 / 200 / 250 / 280 / 350 / 400 / 500 / 700 / 1,000
MGOK (4 Stg.) 1,225 / 1,400 / 1,750 / 2,000 / 2,800 / 3,500 / 5,000 / 7,000 / 10,000
MGOKC 4 / 5 / 7 / 8 / 10 / 21 / 31 / 46 / 61 / 91

Application Direction⁽²⁾: A = 6 o'clock
(For MGOK serie only) B = 9 o'clock
C = 12 o'clock
D = 3 o'clock

Motor Type
Manufacturer and Model

(1) Ratio (I=Nin/Nout). Please refer to the specifications for the ratios provided in each series.

(2) Please refer to page 06.

* Anti-rust cover as option to select.



©2024 by APEX DYNAMICS, INC.
 APEX DYNAMICS, INC. reserves modification and copyrights of all technical specifications, illustrations and drawings in this catalog in allowance for continuous products development and advancement.
 For the newest data and information, please visit <http://www.apexdyna.com/>

Performance - MGO Gearbox

Model No.	Stage	Ratio ⁽¹⁾	MGO115	MGO140	MGO170	MGO240	MGO285	MGO320	
Nominal Output Torque T_{2N} By n_{1N}	1	4	205	380	765	1,415	2,190	4,035	
		5	185	325	660	1,225	1,905	3,505	
		7	135	260	515	980	1,530	2,530	
		10	55	160	315	700	1,070	1,810	
	2	16	195	385	805	1,485	2,295	4,215	
		20	190	370	795	1,495	1,990	3,660	
		21	195	345	700	1,295	2,005	3,685	
		25	195	345	700	1,295	2,005	3,685	
		28	180	345	755	1,510	2,335	4,290	
		31	135	280	560	1,050	1,620	2,590	
		35	195	350	705	1,310	2,030	3,725	
		40	96	220	615	1,260	2,360	4,280	
		46	55	160	335	660	1,005	1,700	
		50	120	275	715	1,325	2,050	3,765	
		61	135	285	585	1,095	1,670	2,675	
		70	135	285	585	1,095	1,670	2,675	
91	55	160	345	660	1,005	1,700			
100	55	160	345	660	1,005	1,700			
Emergency Stop Torque T_{2NOT}	Nm	1,2	4~100	3 times T_{2N}					
Max. Acceleration Torque T_{2B}	Nm	1,2	4~100	1.5 times T_{2N}					
No Load Running Torque ⁽³⁾	Nm	1	4~10	0.7	1.4	3.5	7	11	14
		2	16~100	0.3	0.6	1.3	2.2	3.5	4.5
Backlash ⁽²⁾	arcmin	1	4~10	≤ 3	≤ 3	≤ 3	≤ 3	≤ 3	≤ 3
		2	16~100	≤ 4	≤ 4	≤ 4	≤ 4	≤ 4	≤ 4
Torsional Rigidity	Nm/arcmin	1,2	4~100	22	60	115	395	650	1,050
Nominal Input Speed n_{1N}	rpm	1	4~10	3,600	3,600	3,000	2,700	2,400	2,100
		2	16~100	4,600	4,600	4,000	3,700	3,400	3,100
Max. Input Speed n_{1B}	rpm	1	4~10	6,000	6,000	5,000	4,500	4,000	3,500
		2	16~100	7,000	7,000	6,000	5,500	5,000	4,500
Max. Axial Load F_{2a} ⁽⁴⁾	N	1,2	4~100	2,900	4,070	13,700	29,000	40,000	46,000
Max. Tilting Moment M_{2K} ⁽⁴⁾	Nm	1,2	4~100	1,300	2,180	3,600	10,500	18,400	22,000
Operating Temp	°C	1,2	4~100	-10° C ~ 90° C					
Degree of Gearbox Protection		1,2	4~100	IP67					
Lubrication		1,2	4~100	Lubricant					
Mounting Position		1,2	4~100	All directions					
Running Noise ⁽³⁾	dB(A)	1	4~10	≤ 59	≤ 64	≤ 65	≤ 66	≤ 66	≤ 66
		2	16~100	≤ 59	≤ 60	≤ 63	≤ 66	≤ 66	≤ 66
Efficiency η	%	1	4~10	≥ 97%					
		2	16~100	≥ 94%					

(1) Ratio ($i = N_{in} / N_{out}$).

(2) Backlash is measured at 2% of Nominal Output Torque T_{2N} .

(3) The values are measured by gearbox with ratio 10 (1-stage) or ratio 100 (2-stage), no loading at 3,000 RPM or at the respective Nominal Input Speed by bigger model size.
By lower ratio and/or higher RPM, the values could be higher.

(4) Applied to the output flange center at 100 rpm.

(5) Continuous operation is not recommended.

Inertia - MGO Gearbox

Model No.	MGO115		MGO140		MGO170		MGO240		MGO285		MGO320	
∅ ^(A) (C3)	1-st.	2-st.	1-st.	2-st.	1-st.	2-st.	1-st.	2-st.	1-st.	2-st.	1-st.	2-st.
8	-	-	-	-	-	-	-	-	-	-	-	-
11	-	0.17	-	-	-	-	-	-	-	-	-	-
14	0.53	0.21	-	0.53	-	-	-	-	-	-	-	-
19	0.68	0.63	1.83	0.68	-	1.83	-	-	-	-	-	-
24	4.52	-	5.04	4.52	5.63	5.04	-	5.63	-	-	-	-
28	-	-	6.33	-	7.18	6.33	-	7.18	-	-	-	-
32	-	-	8.73	-	10.1	8.73	12.63	10.1	-	12.63	-	-
35	-	-	14.04	-	15.54	14.04	17.75	15.54	17.35	17.75	28.18	20.8
38	-	-	19.5	-	21.32	19.05	23.26	21.32	23.61	23.26	28.18	27.05
42	-	-	-	-	23.2	-	25.4	23.2	25.5	25.4	30.52	28.95
48	-	-	-	-	56.07	-	61.02	56.07	61.22	61.02	66.85	64.66
55	-	-	-	-	-	-	88.51	-	88.86	-	94.91	-
60	-	-	-	-	-	-	-	-	-	-	117.73	-

(A) ∅ = Input shaft diameter.

-

Flange Shaft - MGO

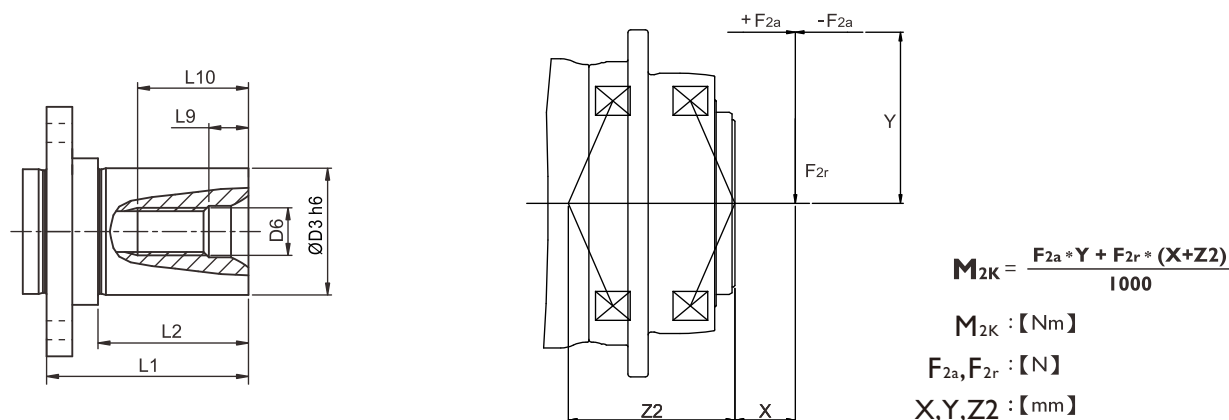

Dimension	L1	L2	D3 h6	D6	L9	L10	Order Code
MGO115	41	30	22	M8	7.2	19	FLS-AH090-S22
			32	M12	10	28	FLS-AH090-S32
MGO140	51	38	32	M12	10	28	FLS-AH110-S32
			40	M16	12	36	FLS-AH110-S40
MGO170	54	38	40	M16	12	36	FLS-AH140-S40
			55	M20	15	42	FLS-AH140-S55
MGO240	73	52	55	M20	15	42	FLS-AH200-S55
			75	M20	15	42	FLS-AH200-S75
MGO285	150	123	90	M24	18	50	FLS-AH255-S90

Note: Dimensions are related to gearbox flange interface.

M2K

MGO / MGOK	115	140	170	240	285	320
Z2 [mm]	81	123.7	104.6	145.7	183.4	196.1

Note : Applied to the output flange center at 100 rpm

Dimension - MGO Gearbox

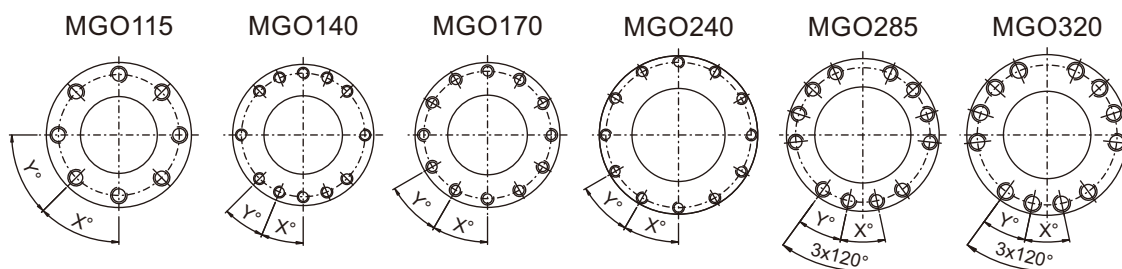
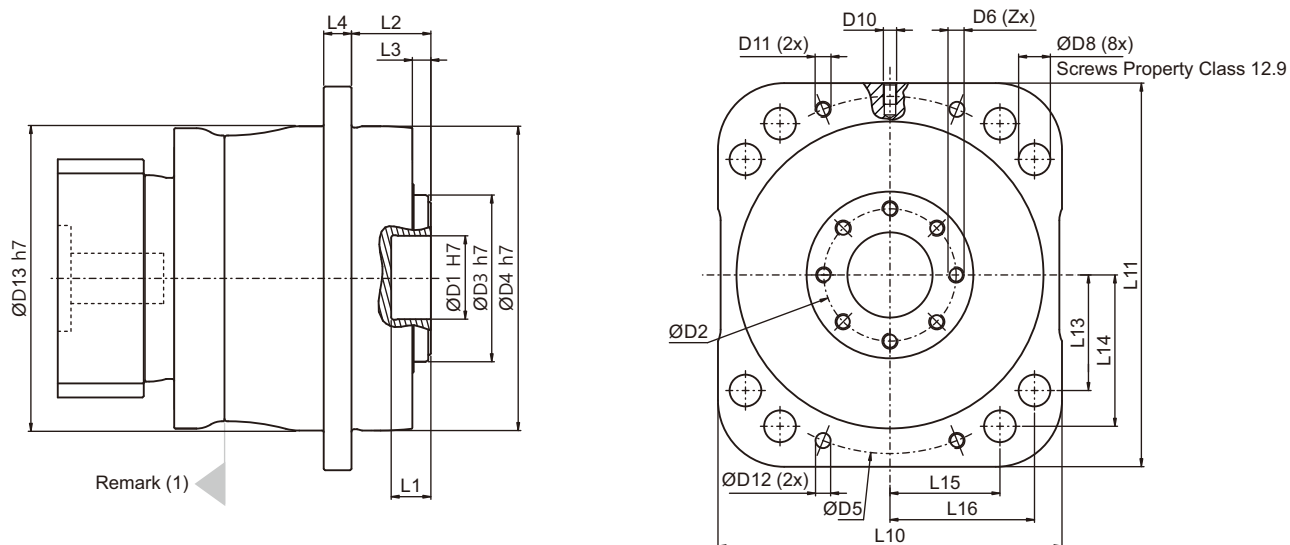

Dimension	MGO115	MGO140	MGO170	MGO240	MGO285	MGO320
D1 H7	31.5	40	50	80	100	100
D2	50	63	80	125	140	160
D3 h7	63	85	100	160	186	208
D4 h7	115	140	170	240	285	320
D5	135	167	200	276	327	368
D6 x Pitch x Deep.	M6x1Px10	M6x1Px11	M8x1.25Px15	M10x1.5Px20	M16x2Px25	M20x2.5Px31
D8	12	14	16.5	20.5	25	29
D8 Fastening Screw*	M8	M10	M12	M16	M20	M24
D10 x Pitch	M5x0.8P	M6x1P	M8x1.25P	M10x1.5P	M12x1.75P	M16x2P
D11 x Pitch	M6x1P	M8x1.25P	M10x1.5P	M12x1.75P	M16x2P	M16x2P
D12	5.7	7.7	9.7	11.7	15.7	15.7
D13 h7	115	143	172	242	285	-
L1	15	15	15	16	16	16
L2	30	41	48	60	70	79.9
L3	7	7	7.5	10	13.5	16.5
L4	10.5	12	15	17	22	25
L10 h8	130	160	190	260	315	350
L11	145	180	215	280	335	390
L13	43.7	54.1	64.8	86.2	100.4	119.2
L14	57.2	70.8	84.8	111.2	132.4	154
L15	41.6	51.4	61.6	90.5	107.3	115.8
L16	54.6	67.6	80.9	113	135.5	148.9
X in Degree	45	22.5	30	30	24	24
Y in Degree	45	22.5	30	30	24	24
Z	8	12	12	12	12	12

(1) Dimensions are related to motor interface. Please contact APEX for details.

* Please apply the special washer provided by APEX.

Application Direction - MGOK Gearbox

Ordering Code : MGOKBI15 - 064 - A / MOTOR

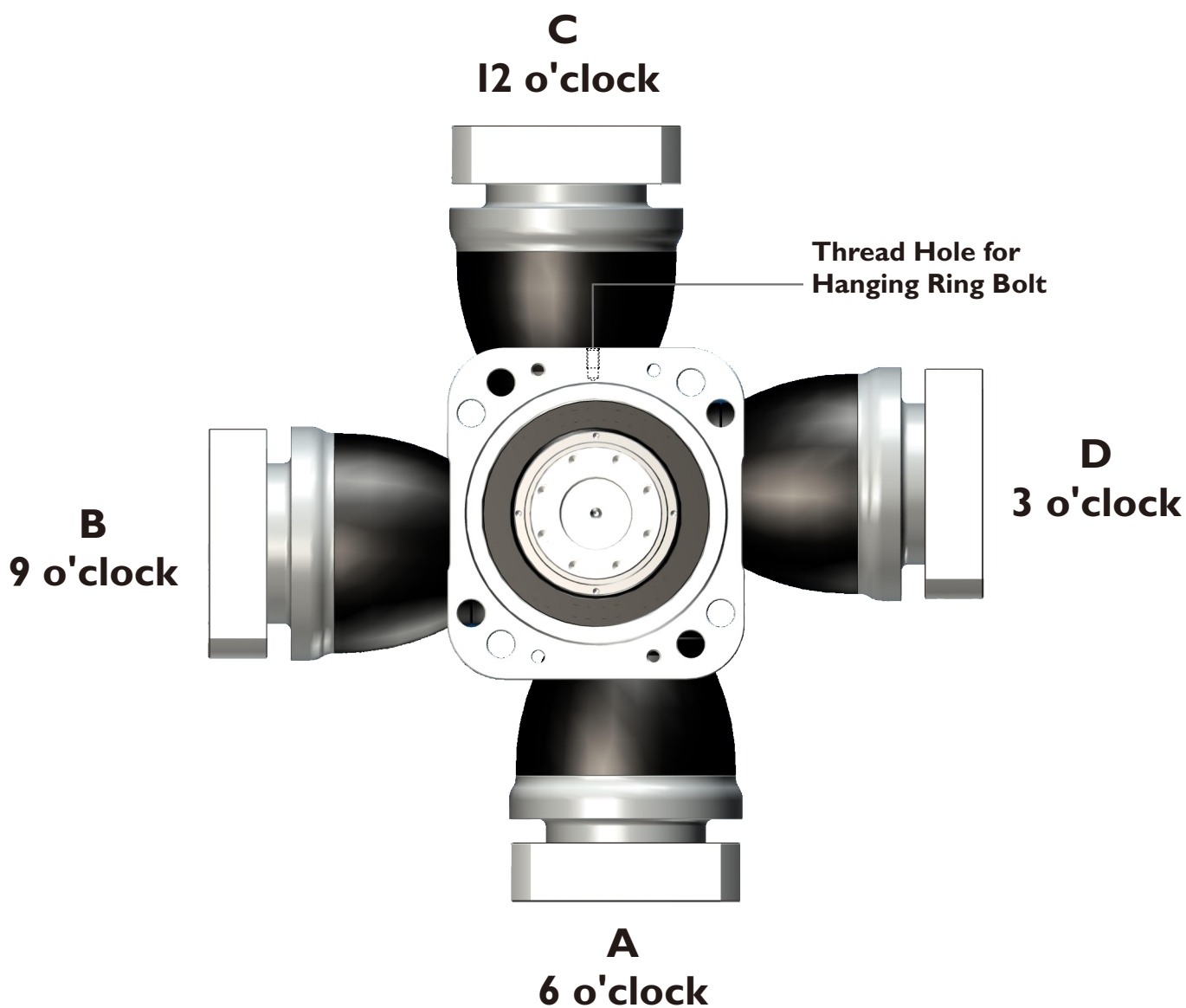

MGOK Gearbox Structure

MGOK Structure

(I) MGOK-2 Stage

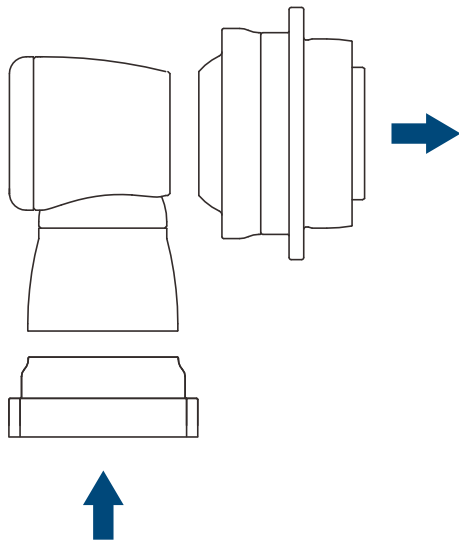

(II) MGOKA-3 Stage

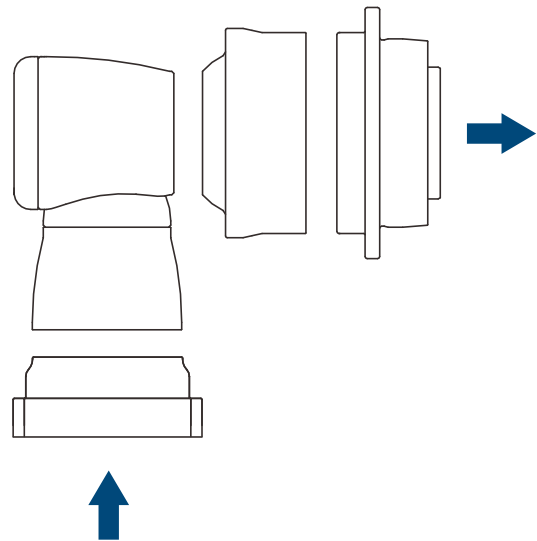

(III) MGOKB-3 Stage

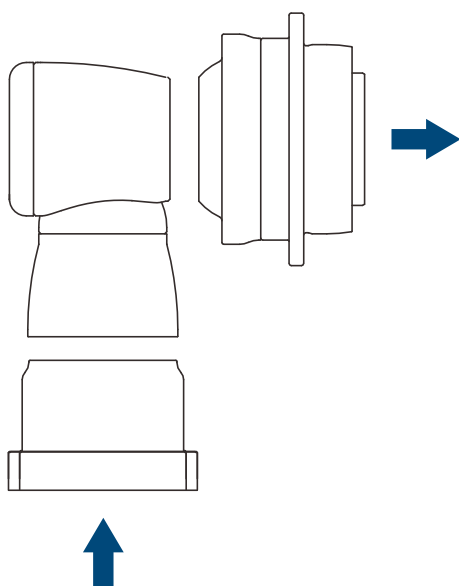

(IV) MGOK-4 Stage

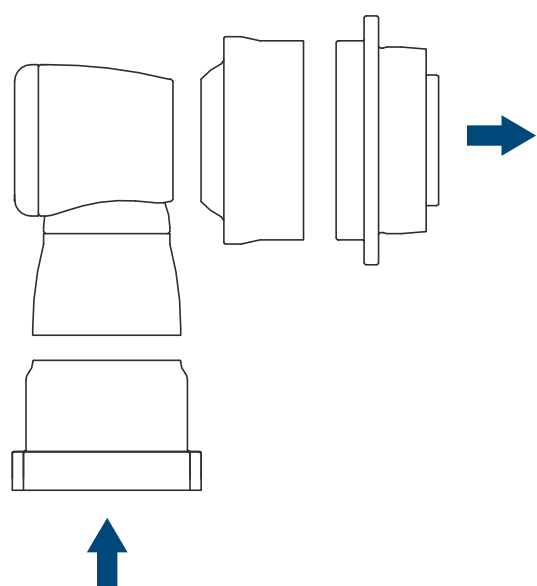

Performance - MGOK (2 Stage) Gearbox

Model No.	Stage	Ratio ⁽¹⁾	MGOK115	MGOK140	MGOK170	MGOK240	MGOK285	MGOK320	
Nominal Output Torque T_{2N} By n_{1N}	Nm	2	12	195	365	805	1,495	1,680	3,280
			15	-	-	-	-	2,005	3,675
			16	185	350	775	1,510	1,680	3,280
			20	180	335	750	1,520	1,780	3,710
			25	195	350	710	1,320	1,775	3,735
			28	170	320	720	1,465	1,560	3,000
			35	190	355	715	1,330	1,950	3,750
			40	160	305	680	1,405	1,440	2,400
			49	135	290	585	1,105	1,680	2,685
			50	185	345	725	1,345	1,800	3,000
		70	135	295	600	1,130	1,710	2,730	
		100	57	160	350	605	915	1,590	
Emergency Stop Torque T_{2NOT}	Nm	2	12~100	2 times T_{2N}					
Max. Acceleration Torque T_{2B}	Nm	2	12~100	1.5 times T_{2N}					
No Load Running Torque ⁽³⁾	Nm	2	12~100	1.3	2	3.1	6	13	16
Backlash ⁽²⁾	arcmin	2	12~100	≤ 4	≤ 4	≤ 4	≤ 4	≤ 4	≤ 4
Torsional Rigidity	Nm/arcmin	2	12~100	27	56	112	389	642	1,275
Nominal Input Speed n_{1N}	rpm	2	12~100	3,000	2,800	2,700	2,200	2,100	2,000
Max. Input Speed n_{1B}	rpm	2	12~100	6,000	6,000	4,500	4,500	4,000	3,000
Max. Axial Load F_{2a} ⁽⁴⁾	N	2	12~100	2,900	4,070	13,700	29,000	40,000	46,000
Max. Tilting Moment M_{2K} ⁽⁴⁾	Nm	2	12~100	1,300	2,180	3,600	10,500	18,400	22,000
Operating Temp	°C	2	12~100	-10° C ~ 90° C					
Degree of Gearbox Protection		2	12~100	IP67					
Lubrication		2	12~100	Lubricant					
Mounting Position		2	12~100	All directions					
Running Noise ⁽³⁾	dB(A)	2	12~100	≤ 66	≤ 68	≤ 68	≤ 70	≤ 70	≤ 72
Efficiency η	%	2	12~100	$\geq 94\%$					

(1) Ratio ($i = N_{in} / N_{out}$).

(2) Backlash is measured at 2% of Nominal Output Torque T_{2N} .

(3) The values are measured by gearbox with ratio 100 (2-stage), no loading at 3,000 RPM or at the respective Nominal Input Speed by bigger model size.
By lower ratio and/or higher RPM, the values could be higher.

(4) Applied to the output flange center at 100 rpm.

(5) Continuous operation is not recommended.

Inertia - MGOK (2 Stage) Gearbox

Model No.	MGOK115	MGOK140	MGOK170	MGOK240	MGOK285	MGOK320
8	-	-	-	-	-	-
11	0.18	-	-	-	-	-
14	0.5	0.52	-	-	-	-
19	0.65	1.69	1.71	-	-	-
24	-	4.89	5.05	6.92	-	-
28	-	-	6.55	6.98	-	-
32	-	-	9.47	10.18	10.18	-
35	-	-	14.91	15.21	15.21	15.68
38	-	-	20.69	20.7	20.7	21.69
42	-	-	-	22.83	22.83	23.59
48	-	-	-	58.45	58.45	59.3

(A) \varnothing = Input shaft diameter.

Dimension - MGOK (2 Stage) Gearbox (Ratio $i = 12 \sim 100$)

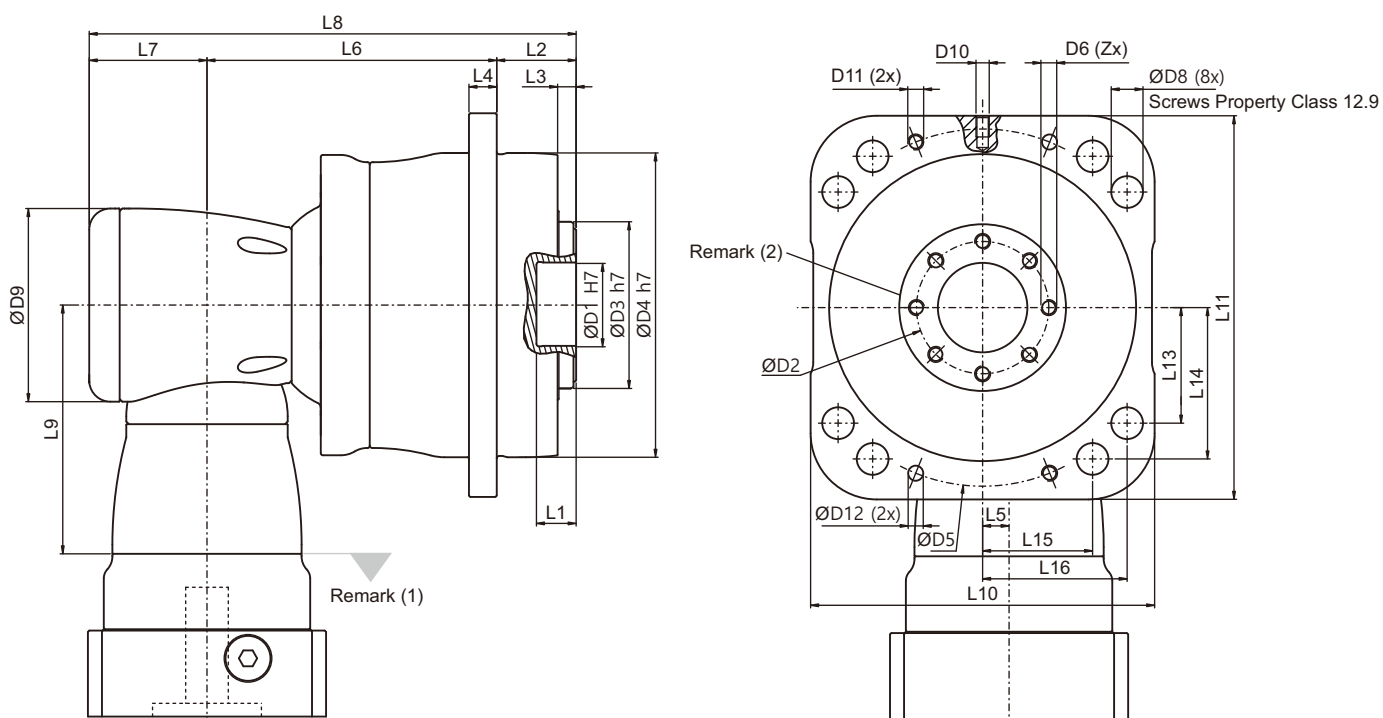

Dimension	MGOK115	MGOK140	MGOK170	MGOK240	MGOK285	MGOK320
D1 H7	31.5	40	50	80	100	100
D2	50	63	80	125	140	160
D3 h7	63	85	100	160	186	208
D4 h7	115	140	170	240	285	320
D5	135	167	200	276	327	368
D6 x Pitch x Deep.	M6x1Px10	M6x1Px11	M8x1.25Px15	M10x1.5Px20	M16x2Px25	M20x2.5Px31
D8	12	14	16.5	20.5	25	29
D8 Fastening Screw*	M8	M10	M12	M16	M20	M24
D9	94	116	163	210	210	255
D10 x Pitch	M5x0.8P	M6x1P	M8x1.25P	M10x1.5P	M12x1.75P	M16x2P
D11 x Pitch	M6x1P	M8x1.25P	M10x1.5P	M12x1.75P	M16x2P	M16x2P
D12	5.7	7.7	9.7	11.7	15.7	15.7
L1	15	15	15	16	16	16
L2	30	41	48	60	70	79.9
L3	7	7	7.5	10	13.5	16.5
L4	10.5	12	15	17	22	25
L5	13	17	25	31	31	36
L6	118	120	156.5	189.9	242.8	272.9
L7	53	68.3	89	115	115	131
L8	201	229.3	293.5	364.9	427.8	483.8
L9	114.5	129	173.5	228	228	265.5
L10 h8	130	160	190	260	315	350
L11	145	180	215	280	335	390
L13	43.7	54.1	64.8	86.2	100.4	119.2
L14	57.2	70.8	84.8	111.2	132.4	154
L15	41.6	51.4	61.6	90.5	107.3	115.8
L16	54.6	67.6	80.9	113	135.5	148.9
X in Degree	45	22.5	30	30	24	24
Y in Degree	45	22.5	30	30	24	24
Z	8	12	12	12	12	12

(1) Dimensions are related to motor interface. Please contact APEX for details.

(2) Refer to the MGO series (Page 05) for flange interface.

* Please apply the special washer provided by APEX.

Performance - MGOKA (3 Stage) Gearbox

Model No.		Stage	Ratio ⁽¹⁾	MGOKA320
Nominal Output Torque T_{2N} By n_{1N}	Nm	3	100	3,875
			125	3,900
			140	3,910
			175	3,930
			200	3,945
			250	3,970
			350	4,000
			500	4,035
			700	3,090
			1,000	1,770
Emergency Stop Torque T_{2NOT}	Nm	3	100~1,000	2 times T_{2N}
Max. Acceleration Torque T_{2B}	Nm	3	100~1,000	1.5 times T_{2N}
No Load Running Torque ⁽³⁾	Nm	3	100~1,000	6
Backlash ⁽²⁾	arcmin	3	100~1,000	≤ 4
Torsional Rigidity	Nm/arcmin	3	100~1,000	1,275
Nominal Input Speed n_{1N}	rpm	3	100~1,000	2,100
Max. Input Speed n_{1B}	rpm	3	100~1,000	4,000
Max. Axial Load F_{2a} ⁽⁴⁾	N	3	100~1,000	46,000
Max. Tilting Moment M_{2K} ⁽⁴⁾	Nm	3	100~1,000	22,000
Operating Temp	°C	3	100~1,000	-10° C ~ 90° C
Degree of Gearbox Protection		3	100~1,000	IP67
Lubrication		3	100~1,000	Lubricant
Mounting Position		3	100~1,000	All directions
Running Noise ⁽³⁾	dB(A)	3	100~1,000	≤ 72
Efficiency η	%	3	100~1,000	$\geq 92\%$

(1) Ratio ($i = N_{in} / N_{out}$).

(2) Backlash is measured at 2% of Nominal Output Torque T_{2N} .

(3) The values are measured by gearbox with ratio 1,000 (3-stage), no loading at 3,000 RPM or at the respective Nominal Input Speed by bigger model size.
By lower ratio and/or higher RPM, the values could be higher.

(4) Applied to the output flange center at 100 rpm.

(5) Continuous operation is not recommended.

Inertia - MGOKA (3 Stage) Gearbox

Model No.		MGOKA320
Input Shaft (C3) $\varnothing^{(A)}$		
32	kg.cm ²	10.18
35		15.21
38		20.7
42		22.83
48		58.45

(A) \varnothing = Input shaft diameter.

Dimension - MGOKA (3 Stage) Gearbox (Ratio i =100~1,000)

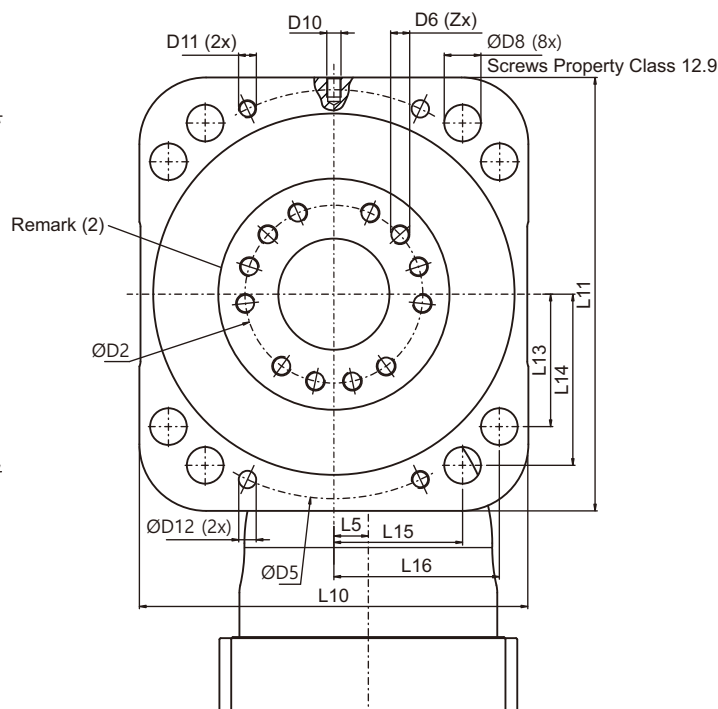
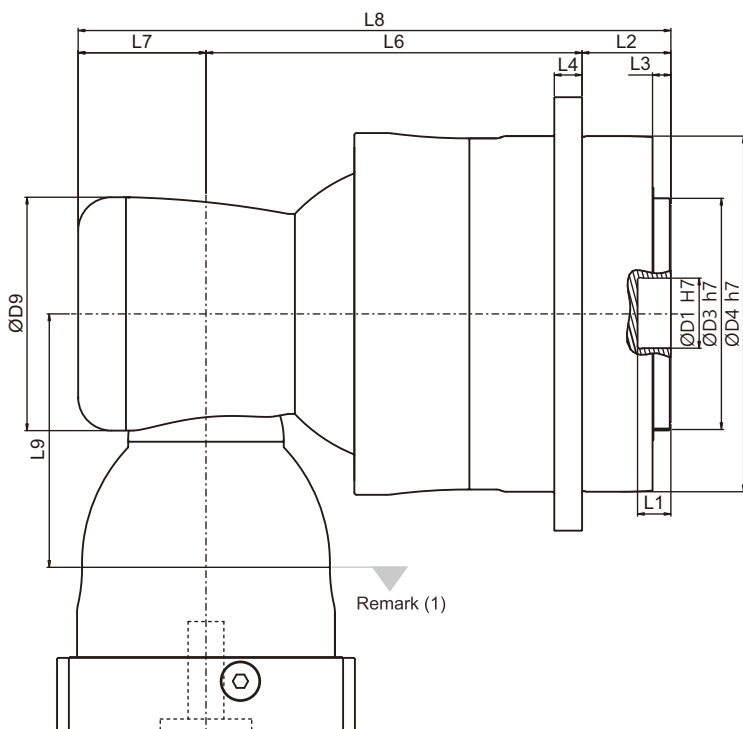

Dimension		MGOKA320
D1	H7	100
D2		160
D3	h7	208
D4	h7	320
D5		368
D6 x Pitch x Deep.		M20x2.5Px3l
D8		29
D8 Fastening Screw*		M24
D9		210
D10 x Pitch		M16x2P
D11 x Pitch		M16x2P
D12		15.7
L1		16
L2		79.9
L3		16.5
L4		25
L5		31
L6		323.4
L7		115
L8		518.3
L9		228
L10	h8	350
L11		390
L13		119.2
L14		154
L15		115.8
L16		148.9
X in Degree		24
Y in Degree		24
Z		12

(1) Dimensions are related to motor interface. Please contact APEX for details.

(2) Refer to the MGO series (Page 05) for flange interface.

* Please apply the special washer provided by APEX.

Performance - MGOKB (3 Stage) Gearbox

Model No.	Stage	Ratio ⁽¹⁾	MGOKB115	MGOKB140	MGOKB170	MGOKB240	MGOKB285	MGOKB320	
Nominal Output Torque T_{2N} By n_{1N}	Nm	3	64	165	310	690	1,425	1,680	3,280
			84	165	300	670	1,380	1,680	3,280
			100	165	290	655	1,355	2,085	3,830
			125	190	330	730	1,355	2,095	3,850
			140	170	285	630	1,310	2,100	3,860
			175	190	325	705	1,370	2,115	3,885
			200	175	290	605	1,265	2,100	3,900
			250	195	335	680	1,380	2,135	3,920
			280	180	300	610	1,230	1,560	3,000
			350	200	345	705	1,395	1,950	3,750
			400	160	330	670	1,330	1,440	2,400
			500	200	380	760	1,405	1,800	3,000
700	135	325	670	1,240	1,875	3,005			
1,000	55	160	380	660	1,065	1,725			
Emergency Stop Torque T_{2NOT}	Nm	3	64~1,000	2 times T_{2N}					
Max. Acceleration Torque T_{2B}	Nm	3	64~1,000	1.5 times T_{2N}					
No Load Running Torque ⁽³⁾	Nm	3	64~1,000	0.2	0.2	0.3	0.4	1	1.2
Backlash ⁽²⁾	arcmin	3	64~1,000	≤ 4	≤ 4	≤ 4	≤ 4	≤ 4	≤ 4
Torsional Rigidity	Nm/arcmin	3	64~1,000	27	56	112	389	642	1,275
Nominal Input Speed n_{1N}	rpm	3	64~1,000	5,500	4,600	4,600	4,000	3,700	3,400
Max. Input Speed n_{1B}	rpm	3	64~1,000	7,000	7,000	7,000	6,000	5,500	5,000
Max. Axial Load F_{2a} ⁽⁴⁾	N	3	64~1,000	2,900	4,070	13,700	29,000	40,000	46,000
Max. Tilting Moment M_{2K} ⁽⁴⁾	Nm	3	64~1,000	1,300	2,180	3,600	10,500	18,400	22,000
Operating Temp	°C	3	64~1,000	-10° C ~ 90° C					
Degree of Gearbox Protection		3	64~1,000	IP67					
Lubrication		3	64~1,000	Lubricant					
Mounting Position		3	64~1,000	All directions					
Running Noise ⁽³⁾	dB(A)	3	64~1,000	≤ 66	≤ 68	≤ 68	≤ 70	≤ 70	≤ 72
Efficiency η	%	3	64~1,000	≥ 92%					

(1) Ratio ($i = N_{in} / N_{out}$).

(2) Backlash is measured at 2% of Nominal Output Torque T_{2N} .

(3) The values are measured by gearbox with ratio 1,000 (3-stage), no loading at 3,000 RPM
or at the respective Nominal Input Speed by bigger model size.

By lower ratio and/or higher RPM, the values could be higher.

(4) Applied to the output flange center at 100 rpm.

(5) Continuous operation is not recommended.

Inertia - MGOKB (3 Stage) Gearbox

Model No. Input Shaft (C3) $\varnothing^{(A)}$	MGOKB115	MGOKB140	MGOKB170	MGOKB240	MGOKB285	MGOKB320
8	0.17	-	-	-	-	-
11	0.17	0.52	-	-	-	-
14	0.21	0.53	1.83	-	-	-
19	-	0.68	1.83	5.6	-	-
24	-	-	5.04	5.63	5.63	-
28	-	-	-	7.18	7.18	-
32	-	-	-	10.1	10.1	12.63
35	-	-	-	15.54	15.54	17.75
38	-	-	-	21.32	21.32	23.26
42	-	-	-	-	23.2	25.4
48	-	-	-	-	56.07	61.02

(A) \varnothing = Input shaft diameter.

Dimension - MGOKB (3 Stage) Gearbox (Ratio $i = 64 \sim 1,000$)

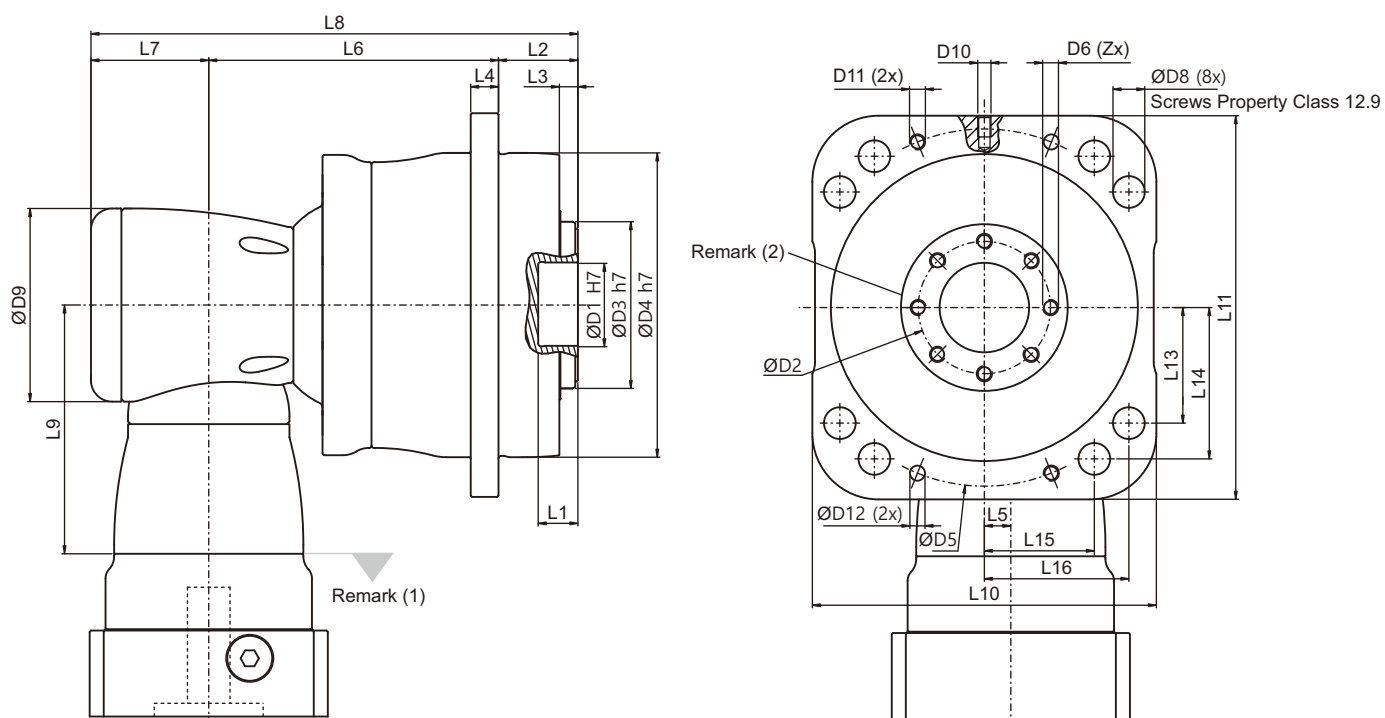

Dimension	MGOKB115	MGOKB140	MGOKB170	MGOKB240	MGOKB285	MGOKB320
D1 H7	31.5	40	50	80	100	100
D2	50	63	80	125	140	160
D3 h7	63	85	100	160	186	208
D4 h7	115	140	170	240	285	320
D5	135	167	200	276	327	368
D6 x Pitch x Deep.	M6x1Px10	M6x1Px11	M8x1.25Px15	M10x1.5Px20	M16x2Px25	M20x2.5Px31
D8	12	14	16.5	20.5	25	29
D8 Fastening Screw*	M8	M10	M12	M16	M20	M24
D9	94	116	163	210	210	255
D10 x Pitch	M5x0.8P	M6x1P	M8x1.25P	M10x1.5P	M12x1.75P	M16x2P
D11 x Pitch	M6x1P	M8x1.25P	M10x1.5P	M12x1.75P	M16x2P	M16x2P
D12	5.7	7.7	9.7	11.7	15.7	15.7
L1	15	15	15	16	16	16
L2	30	41	48	60	70	79.9
L3	7	7	7.5	10	13.5	16.5
L4	10.5	12	15	17	22	25
L5	13	17	25	31	31	36
L6	118	120	156.5	189.9	242.8	272.9
L7	53	68.3	89	115	115	131
L8	201	229.3	293.5	364.9	427.8	483.8
L9	114.5	129	173.5	228	228	265.5
L10 h8	130	160	190	260	315	350
L11	145	180	215	280	335	390
L13	43.7	54.1	64.8	86.2	100.4	119.2
L14	57.2	70.8	84.8	111.2	132.4	154
L15	41.6	51.4	61.6	90.5	107.3	115.8
L16	54.6	67.6	80.9	113	135.5	148.9
X in Degree	45	22.5	30	30	24	24
Y in Degree	45	22.5	30	30	24	24
Z	8	12	12	12	12	12

(1) Dimensions are related to motor interface. Please contact APEX for details.

(2) Refer to the MGO series (Page 05) for flange interface.

* Please apply the special washer provided by APEX.

Performance - MGOK (4 Stage) Gearbox

Model No.		Stage	Ratio ⁽¹⁾	MGOK320
Nominal Output Torque T_{2N} By n_{1N}	Nm	4	1,225	4,070
			1,400	4,085
			1,750	4,100
			2,000	4,120
			2,800	3,185
			3,500	4,180
			5,000	4,285
			7,000	3,445
			10,000	2,240
Emergency Stop Torque T_{2NOT}	Nm	4	1,225~10,000	2 times T_{2N}
Max. Acceleration Torque T_{2B}	Nm	4	1,225~10,000	1.5 times T_{2N}
No Load Running Torque ⁽³⁾	Nm	4	1,225~10,000	0.4
Backlash ⁽²⁾	arcmin	4	1,225~10,000	≤ 4
Torsional Rigidity	Nm/arcmin	4	1,225~10,000	1,275
Nominal Input Speed n_{1N}	rpm	4	1,225~10,000	3,700
Max. Input Speed n_{1B}	rpm	4	1,225~10,000	5,500
Max. Axial Load F_{2a} ⁽⁴⁾	N	4	1,225~10,000	46,000
Max. Tilting Moment M_{2K} ⁽⁴⁾	Nm	4	1,225~10,000	22,000
Operating Temp	°C	4	1,225~10,000	-10° C ~ 90° C
Degree of Gearbox Protection		4	1,225~10,000	IP67
Lubrication		4	1,225~10,000	Lubricant
Mounting Position		4	1,225~10,000	All directions
Running Noise ⁽³⁾	dB(A)	4	1,225~10,000	≤ 72
Efficiency η	%	4	1,225~10,000	$\geq 90\%$

(1) Ratio ($i = N_{in} / N_{out}$).

(2) Backlash is measured at 2% of Nominal Output Torque T_{2N} .

(3) The values are measured by gearbox with ratio 10,000 (4-stage), no loading at 3,000 RPM or at the respective Nominal Input Speed by bigger model size.
By lower ratio and/or higher RPM, the values could be higher.

(4) Applied to the output flange center at 100 rpm.

(5) Continuous operation is not recommended.

Inertia - MGOK (4 Stage) Gearbox

Model No.		MGOK320
Input Shaft (C3) \varnothing ^(A)	kg.cm ²	
24		5.63
28		7.18
32		10.1
35		15.54
38	21.32	

(A) \varnothing = Input shaft diameter.

Dimension - MGOK (4 Stage) Gearbox (Ratio i = 1,225~10,000)

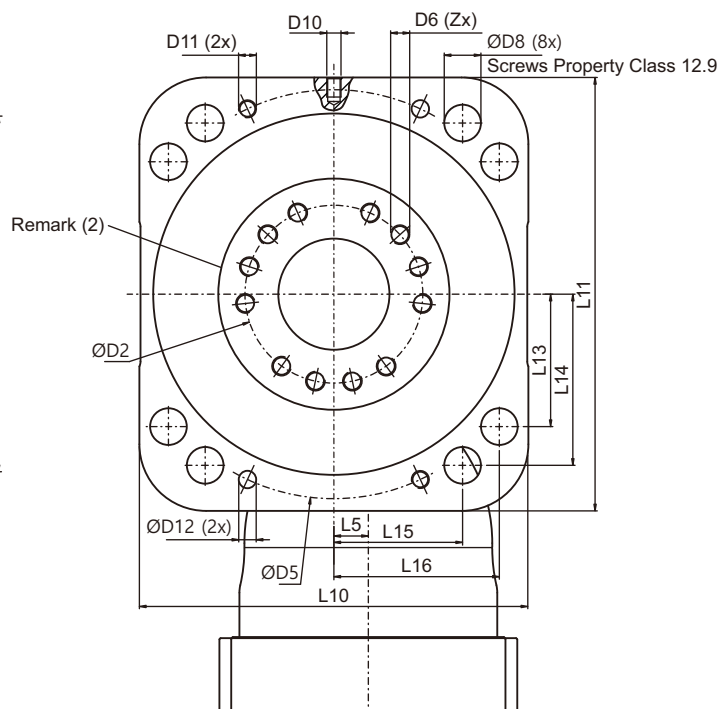
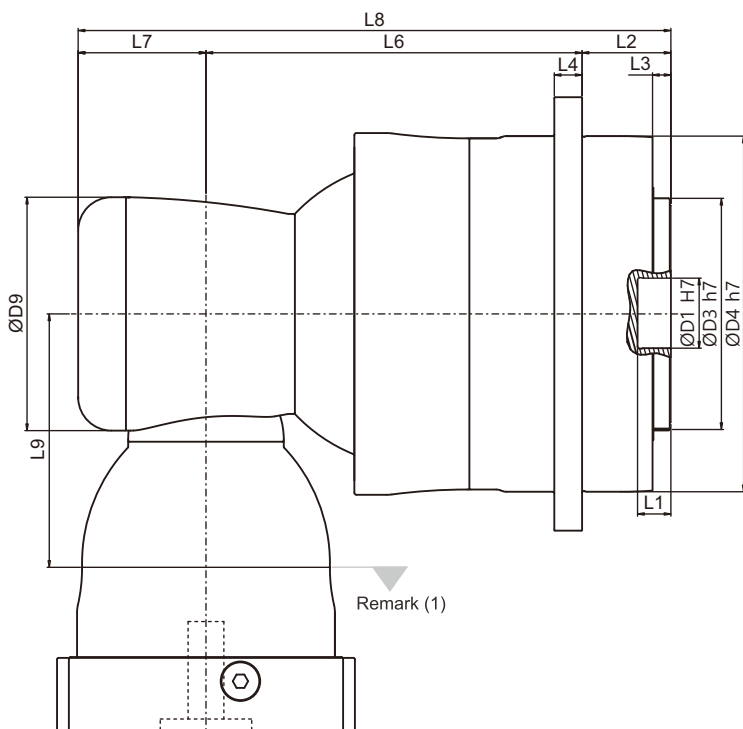

Dimension		MGOK320
D1	H7	100
D2		160
D3	h7	208
D4	h7	320
D5		368
D6 x Pitch x Deep.		M20x2.5Px3l
D8		29
D8 Fastening Screw*		M24
D9		210
D10 x Pitch		M16x2P
D11 x Pitch		M16x2P
D12		15.7
L1		16
L2		79.9
L3		16.5
L4		25
L5		31
L6		323.4
L7		115
L8		518.3
L9		228
L10	h8	350
L11		390
L13		119.2
L14		154
L15		115.8
L16		148.9
X in Degree		24
Y in Degree		24
Z		12

(1) Dimensions are related to motor interface. Please contact APEX for details.

(2) Refer to the MGO series (Page 05) for flange interface.

* Please apply the special washer provided by APEX.

Performance - MGOKC Gearbox

Model No.		Stage	Ratio ⁽¹⁾	MGOKC115	MGOKC140	MGOKC170	MGOKC240	MGOKC285	MGOKC320
Nominal Output Torque T_{2N} By n_{1N}	Nm	2	4	205	380	775	1,440	2,240	4,160
			5	185	330	670	1,250	1,930	3,610
			7	135	260	525	1,000	1,565	2,535
			8	205	395	800	1,320	2,300	4,260
		3	10	190	340	690	1,290	2,000	3,700
			21	195	345	700	1,310	2,045	3,750
			31	135	275	565	1,070	1,665	2,660
			46	57	160	340	660	1,000	1,710
			61	135	285	590	1,115	1,720	2,750
			91	57	160	350	660	985	1,600
Emergency Stop Torque T_{2NOT}	Nm	2,3	4~91	2 times T_{2N}					
Max. Acceleration Torque T_{2B}	Nm	2,3	4~91	1.5 times T_{2N}					
No Load Running Torque ⁽³⁾	Nm	2	4~10	2.5	5.8	12	25	48	95
		3	21~91	1.5	2.5	4	9	18.5	35
Backlash ⁽²⁾	arcmin	2	4~10	≤ 4	≤ 4	≤ 4	≤ 4	≤ 4	≤ 4
		3	21~91	≤ 4	≤ 4	≤ 4	≤ 4	≤ 4	≤ 4
Torsional Rigidity	Nm/arcmin	2,3	4~91	27	56	112	389	642	1,275
Nominal Input Speed n_{1N}	rpm	2	4~10	3,600	3,000	2,300	1,800	1,500	1,100
		3	21~91	4,600	4,000	3,000	2,300	1,800	1,500
Max. Input Speed n_{1B}	rpm	2	4~10	6,000	5,500	4,500	3,500	3,000	2,200
		3	21~91	7,000	6,500	5,500	4,500	3,500	3,000
Max. Axial Load F_{2a} ⁽⁴⁾	N	2,3	4~91	2,900	4,070	13,700	29,000	40,000	46,000
Max. Tilting Moment M_{2K} ⁽⁴⁾	Nm	2,3	4~91	1,300	2,180	3,600	10,500	18,400	22,000
Operating Temp	°C	2,3	4~91	-10° C ~ 90° C					
Degree of Gearbox Protection		2,3	4~91	IP67					
Lubrication		2,3	4~91	Lubricant					
Mounting Position		2,3	4~91	All directions					
Running Noise ⁽³⁾	dB(A)	2	4~10	≤ 68	≤ 68	≤ 70	≤ 70	≤ 72	≤ 74
		3	21~91	≤ 68	≤ 68	≤ 70	≤ 70	≤ 72	≤ 74
Efficiency η	%	2	4~10	≥ 95%					
		3	21~91	≥ 93%					

(1) Ratio ($i = N_{in} / N_{out}$).

(2) Backlash is measured at 2% of Nominal Output Torque T_{2N} .

(3) The values are measured by gearbox with ratio 10 (2-stage) or ratio 91 (3-stage), no loading at 3,000 RPM or at the respective Nominal Input Speed by bigger model size.

By lower ratio and/or higher RPM, the values could be higher.

(4) Applied to the output flange center at 100 rpm.

(5) Continuous operation is not recommended.

Inertia MGOKC Gearbox (Ratio $i = 4\sim 10 / 21\sim 91$)

Model No.	MGOKC115		MGOKC140		MGOKC170		MGOKC240		MGOKC285		MGOKC320	
	2-st.	3-st.	2-st.	3-st.	2-st.	3-st.	2-st.	3-st.	2-st.	3-st.	2-st.	3-st.
8	-	0.1	-	-	-	-	-	-	-	-	-	-
11	0.52	0.17	-	-	-	-	-	-	-	-	-	-
14	0.52	0.21	-	0.52	-	-	-	-	-	-	-	-
19	1.69	0.62	1.71	1.69	-	1.71	-	-	-	-	-	-
24	4.89	-	5.05	4.89	6.92	5.05	-	6.92	-	-	-	-
28	-	-	6.55	-	6.98	6.55	-	6.98	-	-	-	-
32	-	-	9.47	-	10.18	9.47	10.18	10.18	-	10.18	-	-
35	-	-	14.91	-	15.21	14.91	15.21	15.21	15.68	15.21	23.46	15.68
38	-	-	20.69	-	20.7	20.69	20.7	20.7	21.69	20.7	23.46	21.69
42	-	-	-	-	22.83	-	22.83	22.83	23.59	22.83	25.28	23.59
48	-	-	-	-	58.45	-	58.45	58.45	59.3	58.45	61.61	59.3
55	-	-	-	-	-	-	-	-	86.95	-	89.67	-
60	-	-	-	-	-	-	-	-	-	-	112.49	-

(A) \varnothing = Input shaft diameter.

Dimension - MGOKC Gearbox (Ratio i = 4~10 / 21~91)

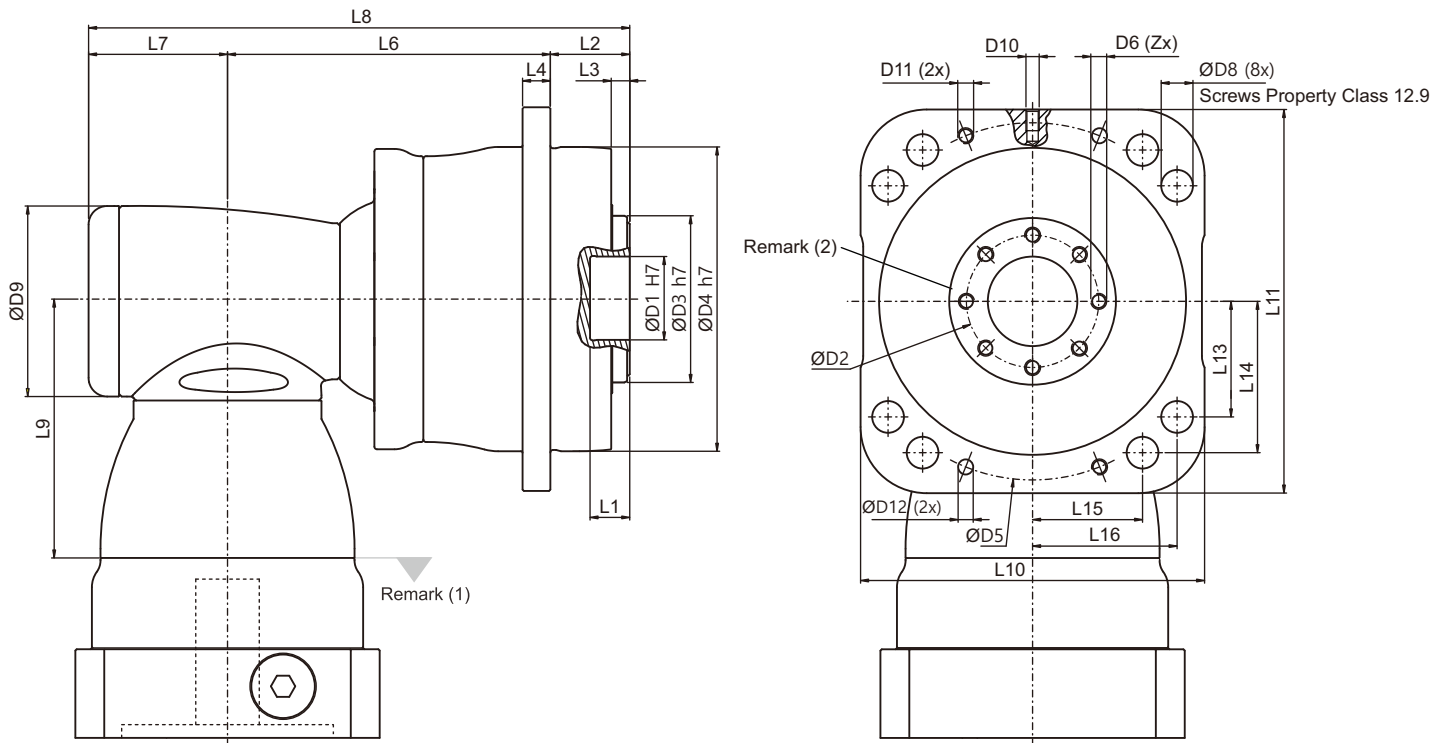

Dimension	MGOKC115		MGOKC140		MGOKC170		MGOKC240		MGOKC285		MGOKC320	
	2-st.	3-st.	2-st.	3-st.	2-st.	3-st.	2-st.	3-st.	2-st.	3-st.	2-st.	3-st.
D1 H7	31.5		40		50		80		100		100	
D2	50		63		80		125		140		160	
D3 h7	63		85		100		160		186		208	
D4 h7	115		140		170		240		285		320	
D5	135		167		200		276		327		368	
D6 x Pitch x Deep.	M6x1Px10		M6x1Px11		M8x1.25Px15		M10x1.5Px20		M16x2Px25		M20x2.5Px31	
D8	12		14		16.5		20.5		25		29	
D8 Fastening Screw*	M8		M10		M12		M16		M20		M24	
D9	94	64	116	92	156	116	156	156	195	156	240	195
D10 x Pitch	M5x0.8P		M6x1P		M8x1.25P		M10x1.5P		12x1.75P		M16x2P	
D11 x Pitch	M6x1P		M8x1.25P		M10x1.5P		M12x1.75P		M16x2P		M16x2P	
D12	5.7		7.7		9.7		11.7		15.7		15.7	
L1	15		15		15		16		16		16	
L2	30		41		48		60		70		79.9	
L3	7		7		7.5		10		13.5		16.5	
L4	10.5		12		15		17		22		25	
L6	128	149	130.5	148	184.5	183.5	199.9	259.4	250.3	315.8	288.9	330.9
L7	61.5	46.5	76	61.5	97.5	76	97.5	97.5	105.5	97.5	141	105.5
L8	219.5	225.5	247.5	250.5	330	307.5	357.4	416.9	425.8	483.3	509.8	516.3
L9	113.5	81.5	147.5	113.5	196.5	147.5	196.5	196.5	229	196.5	260	229
L10 h8	130		160		190		260		315		350	
L11	145		180		215		280		335		390	
L13	43.7		54.1		64.8		86.2		100.4		119.2	
L14	57.2		70.8		84.8		111.2		132.4		154	
L15	41.6		51.4		61.6		90.5		107.3		115.8	
L16	54.6		67.6		80.9		113		135.5		148.9	
X in Degree	45		22.5		30		30		24		24	
Y in Degree	45		22.5		30		30		24		24	
Z	8		12		12		12		12		12	

(1) Dimensions are related to motor interface. Please contact APEX for details.

(2) Refer to the MGO series (Page 05) for flange interface.

* Please apply the special washer provided by APEX.

Gearbox Series - MGOH / MGOHK / MGOHC / MGOHCK

► Features:

- Enhanced Axial and Radial Load
- Enlarged Holes on Flange for Easy Installation and Adjustment
- **Extra High Torque**
- High Torsional Rigidity
- High Precision
- Long-Term Persistence of Low Backlash
- Long Service Life
- High Efficiency / Optimized Inertia Moment
- Identical Input-Output Rotating Direction with Hypoid Right-Angle K-Series
- Standard Flange or Curvic Output



Ordering Code - MGOH / MGOHK Series

MGOHI 15	—	004	/	MOTOR
MGOHKI 15	—	016	— A	MOTOR
MGOHCKI 15				Motor Type
				Application Direction
				Ratio
				Gearbox Size

Gearbox Size

MGOH	115 / 140 / 170 / 240 / 285 / 320
MGOHC	115 / 140 / 170 / 240 / 285 / 320
MGOHK	115 / 140 / 170 / 240 / 285 / 320
MGOHCK	115 / 140 / 170 / 240 / 285 / 320

Ratio⁽¹⁾

MGOH/MGOHC	(1 Stg.) 4 / 5.5
MGOH/MGOHC	(2 Stg.) 16 / 20 / 22 / 27.5 / 28 / 38.5 / 40 / 55
MGOH/MGOHC	(3 Stg.) 64 / 88 / 100 / 110 / 140 / 154 / 160 / 200 / 220 / 280 / 400
MGOHK/MGOHCK	(2 Stg.) 4 / 5.5 / 8 / 11
MGOHK/MGOHCK	(2 Stg.) 16 / 20 / 22 / 27.5 / 28 / 38.5 / 40 / 55
MGOHK/MGOHCK	(3 Stg.) 64 / 88 / 100 / 110 / 137.5 / 140 / 154 / 160 / 200 / 220 / 280 / 385
MGOHK/MGOHCK	(4 Stg.) 400 / 440 / 500 / 550 / 700 / 770 / 1000 / 1078 / 1400 / 1540 / 1600 / 2000 / 2695 / 2800 / 3850 / 4000 / 5500

Application Direction⁽²⁾: A = 6 o'clock
 (For MGOHK / MGOHCK series only) **B = 9 o'clock**
C = 12 o'clock
D = 3 o'clock

Motor Type
Manufacturer and Model

(1) Ratio (I=N_{in}/N_{out}). Please refer to the specifications for the ratios provided in each series.
 (2) Please refer to page 06.
 * Anti-rust cover as option to select.



©2024 by APEX DYNAMICS, INC.
 APEX DYNAMICS, INC. reserves modification and copyrights of all technical specifications, illustrations and drawings in this catalog in allowance for continuous products development and advancement.
 For the newest data and information, please visit <http://www.apexdyna.com/>

Performance - MGOH / MGOHC Gearbox

Model No.		Stage	Ratio ⁽¹⁾	MGOH 115 MGOHC 115	MGOH 140 MGOHC 140	MGOH 170 MGOHC 170	MGOH 240 MGOHC 240	MGOH 285 MGOHC 285	MGOH 320 MGOHC 320
Nominal Output Torque T_{2N} By n_{1N}	Nm	1	4	205	505	790	1,885	2,920	5,380
			5.5	230	435	735	1,635	2,535	4,580
		2	16	255	485	890	1,980	3,055	5,615
			20	245	470	860	1,995	3,080	5,660
			22	240	460	770	1,710	2,640	4,755
			27.5	240	460	775	1,720	2,660	4,785
			28	235	445	820	2,015	3,110	5,720
			38.5	245	465	785	1,740	2,690	4,830
			40	96	225	650	1,610	3,145	5,780
		3	55	130	315	795	1,740	2,715	4,875
			64	210	400	745	1,850	3,040	5,840
			88	250	470	800	1,780	2,720	4,920
			100	215	380	705	1,760	2,900	5,780
			110	250	475	810	1,790	2,760	4,945
			140	220	365	680	1,700	2,810	5,595
			154	250	480	815	1,805	2,785	4,980
			160	210	370	670	1,680	2,775	5,530
200	225		375	655	1,645	2,715	5,420		
220	255		480	825	1,820	2,810	5,020		
		280	230	385	655	1,595	2,640	5,265	
		400	100	235	675	1,590	2,645	5,375	
Emergency Stop Torque T_{2NOT}	Nm	1,2,3	4~400	3 times T_{2N}					
Max. Acceleration Torque T_{2B}	Nm	1,2,3	4~400	1.5 times T_{2N}					
No Load Running Torque ⁽²⁾	Nm	1	4~5.5	1.5	2.5	7.1	14	22	28
		2	16~55	0.6	1.1	3.7	8	12	18
		3	64~400	0.35	0.7	1.6	4	4.5	6.5
Backlash ⁽³⁾	arcmin	1	4~5.5	≤ 3					
		2,3	16~400	≤ 4					
Torsional Rigidity	Nm/arcmin	1,2,3	4~400	42	95	205	650	1,200	1,800
Nominal Input Speed n_{1N}	rpm	1	4~5.5	3,600	3,600	3,000	2,700	2,400	2,100
		2	16~55	4,600	4,600	4,000	3,700	3,400	3,100
		3	64~400	5,000	5,000	4,600	4,000	3,700	3,400
Max. Input Speed n_{1B}	rpm	1	4~5.5	6,000	6,000	5,000	4,500	4,000	3,500
		2	16~55	7,000	7,000	6,000	5,500	5,000	4,500
		3	64~400	7,000	7,000	7,000	6,000	5,500	5,000
Max. Axial Load F_{2a} ⁽⁴⁾	N	1,2,3	4~400	2,900	4,070	13,700	29,000	40,000	46,000
Max. Tilting Moment M_{2K} ⁽⁴⁾	Nm	1,2,3	4~400	1,300	2,180	3,600	10,500	18,400	22,000
Operating Temp.	°C	1,2,3	4~400	-10° C ~ 90° C					
Degree of Gearbox Protection		1,2,3	4~400	IP67					
Lubrication		1,2,3	4~400	Lubricant					
Mounting Position		1,2,3	4~400	All directions					
Running Noise ⁽²⁾	dB(A)	1	4~5.5	≤ 59	≤ 64	≤ 66	≤ 66	≤ 68	≤ 68
		2	16~55	≤ 60	≤ 62	≤ 64	≤ 66	≤ 67	≤ 67
		3	64~400	≤ 60	≤ 62	≤ 64	≤ 66	≤ 66	≤ 67
Efficiency η	%	1	4~5.5	≥ 97%					
		2	16~55	≥ 94%					
		3	64~400	≥ 92%					

- (1) Ratio ($i = N_{in} / N_{out}$) .
- (2) The values are measured by gearbox with ratio 5.5 (1-stage), 55 (2-stage) or ratio 220 (3-stage), no loading at 3,000 RPM or at the respective Nominal Input Speed by bigger model size.
By lower ratio and/or higher RPM, the values could be higher.
- (3) Backlash is measured at 2% of Nominal Output Torque T_{2N} .
- (4) Applied to the output flange/curvic center at 100 rpm. The calculation formula please refer to Fig. 1.
- (5) Continuous operation is not recommended.

$$\text{Max. Tilting Moment } M_{2K} = \frac{F_{2a} * Y + F_{2r} * (X+Z2)}{1000}$$

M_{2K} : [Nm]
 F_{2a}, F_{2r} : [N]
 $X, Y, Z2$: [mm]

MGOH / MGOHK MGOHC/MGOHCK	115	140	170	240	285	320
Z2 [mm]	81	123.7	104.6	145.7	183.4	196.1

Note : Applied to the output flange center at 100 rpm.

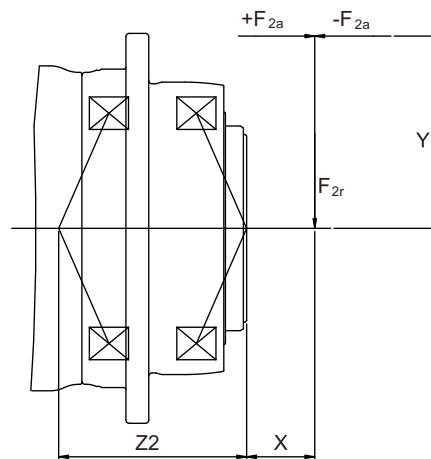

Fig. 1

Max. Inertia - MGOH / MGOHC Gearbox

Model No.		MGOH 115 MGOHC 115			MGOH 140 MGOHC 140			MGOH 170 MGOHC 170			MGOH 240 MGOHC 240			MGOH 285 MGOHC 285		
Ø ^(A)	Stage	1	2	3	1	2	3	1	2	3	1	2	3	1	2	3
11	kg.cm ²	-	-	0.16	-	-	-	-	-	-	-	-	-	-	-	-
14		0.42	0.21	0.19	-	-	0.21	-	-	-	-	-	-	-	-	-
19		0.66	0.6	-	1.84	0.66	0.6	-	-	0.66	-	-	-	-	-	-
24		3.94	-	-	4.11	3.94	-	4.61	4.11	3.94	-	-	4.11	-	-	-
28		-	-	-	5.48	-	-	6.14	5.48	-	-	-	5.48	-	-	6.14
32		-	-	-	7.36	-	-	8.17	7.36	-	-	8.17	7.36	-	-	8.17
35		-	-	-	14.04	-	-	15.54	14.04	-	17.75	15.54	14.04	-	17.75	15.54
38		-	-	-	16.71	-	-	18.19	16.71	-	20.17	18.19	16.71	-	20.17	18.19
42		-	-	-	-	-	-	23.2	-	-	25.4	23.2	-	28.88	25.4	-
48		-	-	-	-	-	-	52.42	-	-	55.18	52.42	-	58.64	55.18	-
55		-	-	-	-	-	-	-	-	-	88.51	-	-	92.48	-	-
60		-	-	-	-	-	-	-	-	-	-	-	-	-	-	-

Model No.		MGOH 320 MGOHC 320		
Ø ^(A)	Stage	1	2	3
11	kg.cm ²	-	-	-
14		-	-	-
19		-	-	-
24		-	-	-
28		-	-	-
32		-	-	-
35		-	-	17.75
38		-	23.66	20.17
42		-	28.88	25.4
48		69.78	58.64	55.18
55		104.22	92.48	-
60		127.69	-	-

(A) Ø = Input shaft diameter.

Dimension - MGOH Gearbox

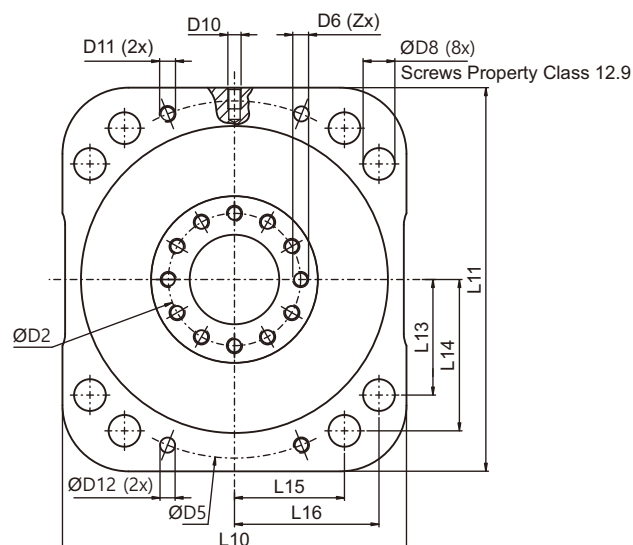
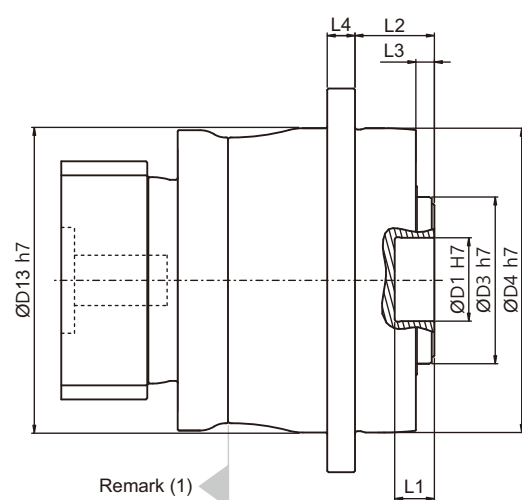

MGOH115

MGOH140

MGOH170

MGOH240

MGOH285

MGOH320

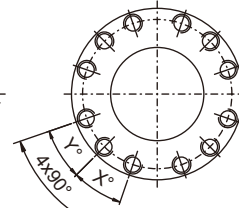
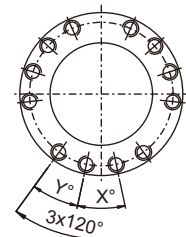
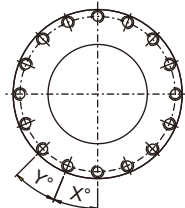
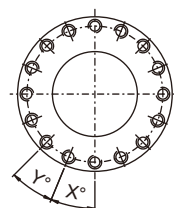
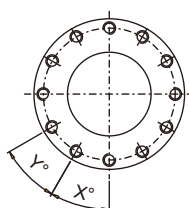
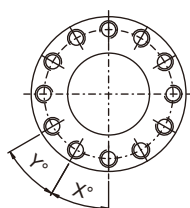

Dimension	MGOH115	MGOH140	MGOH170	MGOH240	MGOH285	MGOH320
D1 H7	31.5	40	50	80	100	100
D2	50	63	80	125	140	160
D3 h7	63	85	100	160	186	208
D4 h7	115	140	170	240	285	320
D5	135	167	200	276	327	368
D6 x Pitch x Deep.	M6x1Px11	M8x1.25Px12	M8x1.25Px15	M10x1.5Px20	M16x2Px25	M24x3Px37
D8	12	14	16.5	20.5	25	29
D8 Fastening Screw*	M8	M10	M12	M16	M20	M24
D10 x Pitch	M5x0.8P	M6x1P	M8x1.25P	M10x1.5P	M12x1.75P	M16x2P
D11 x Pitch	M6x1P	M8x1.25P	M10x1.5P	M12x1.75P	M16x2P	M16x2P
D12	5.7	7.7	9.7	11.7	15.7	15.7
D13 h7	115	143	172	242	285	—
L1	15	15	15	16	16	16
L2	30	41	48	60	70	79.9
L3	7	7	7.5	10	13.5	16.5
L4	10.5	12	15	17	22	25
L10 h8	130	160	190	260	315	350
L11	145	180	215	280	335	390
L13	43.7	54.1	64.8	86.2	100.4	119.2
L14	57.2	70.8	84.8	111.2	132.4	154
L15	41.6	51.4	61.6	90.5	107.3	115.8
L16	54.6	67.6	80.9	113	135.5	148.9
X in Degree	30	30	22.5	22.5	24	26
Y in Degree	30	30	22.5	22.5	24	26
Z	12	12	16	16	12	12

(1) Dimensions are related to motor interface. Please contact APEX for details.

* Please apply the special washer provided by APEX.

Dimension - MGOHC Gearbox

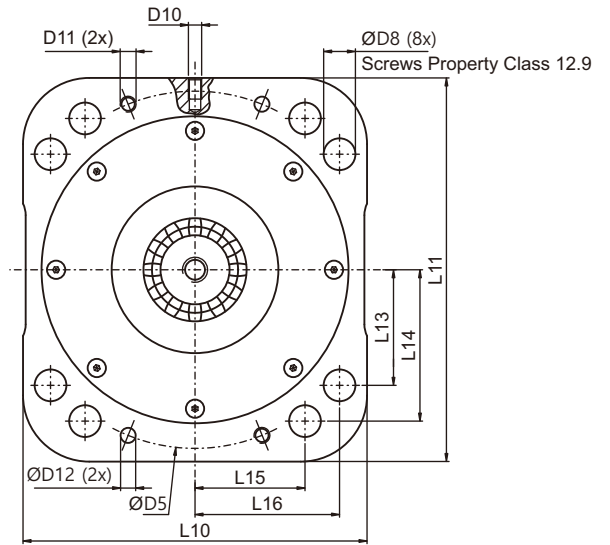
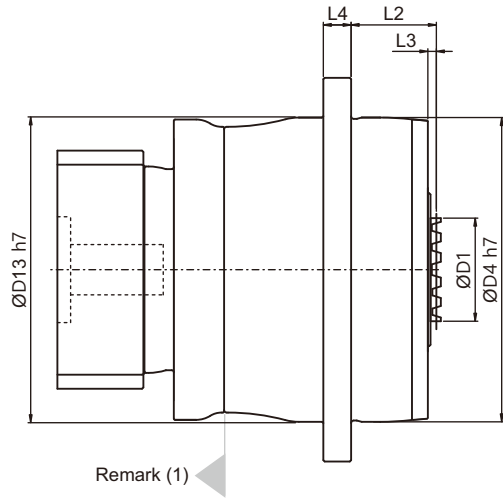

Dimension	MGOHC115	MGOHC140	MGOHC170	MGOHC240	MGOHC285	MGOHC320
D1	36	46	68	108	120	132
D4 h7	115	140	170	240	285	320
D5	135	167	200	276	327	368
D8	12	14	16.5	20.5	25	29
D8 Fastening Screw*	M8	M10	M12	M16	M20	M24
D10 x Pitch	M5x0.8P	M6x1P	M8x1.25P	M10x1.5P	M12x1.75P	M16x2P
D11 x Pitch	M6x1P	M8x1.25P	M10x1.5P	M12x1.75P	M16x2P	M16x2P
D12	5.7	7.7	9.7	11.7	15.7	15.7
D13 h7	115	143	172	242	285	-
L2	32.5	46.5	54.5	70	80.5	90.4
L3	3.5	6.5	7.5	11	11.5	11.5
L4	10.5	12	15	17	22	25
L10 h8	130	160	190	260	315	350
L11	145	180	215	280	335	390
L13	43.7	54.1	64.8	86.2	100.4	119.2
L14	57.2	70.8	84.8	111.2	132.4	154
L15	41.6	51.4	61.6	90.5	107.3	115.8
L16	54.6	67.6	80.9	113	135.5	148.9

(1) Dimensions are related to motor interface. Please contact APEX for details.

* Please apply the special washer provided by APEX.

MGOHK Gearbox Structure

MGOHK Structure

(I) MGOHK / MGOHCK-2 Stage

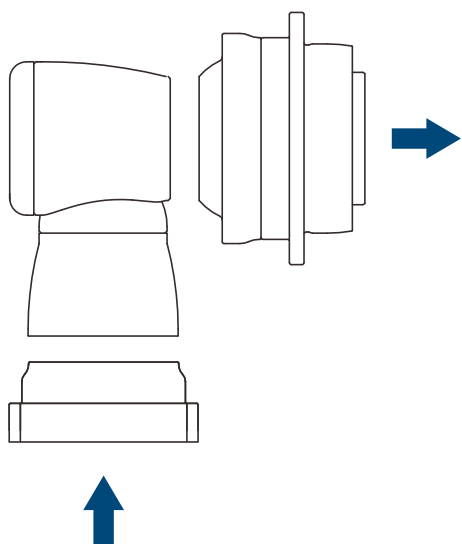

(II) MGOHK / MGOHCK-3 Stage

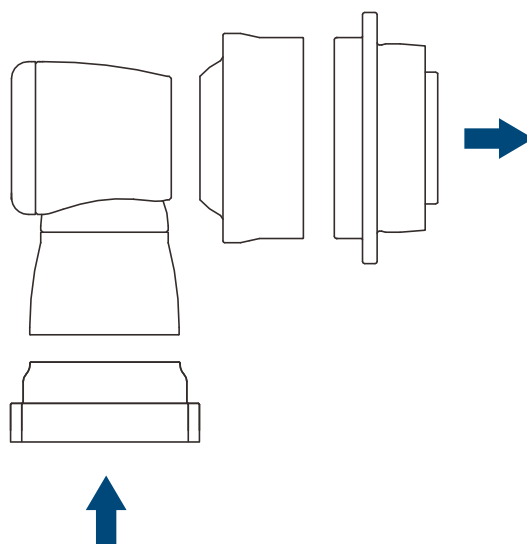

(III) MGOHK / MGOHCK-4 Stage

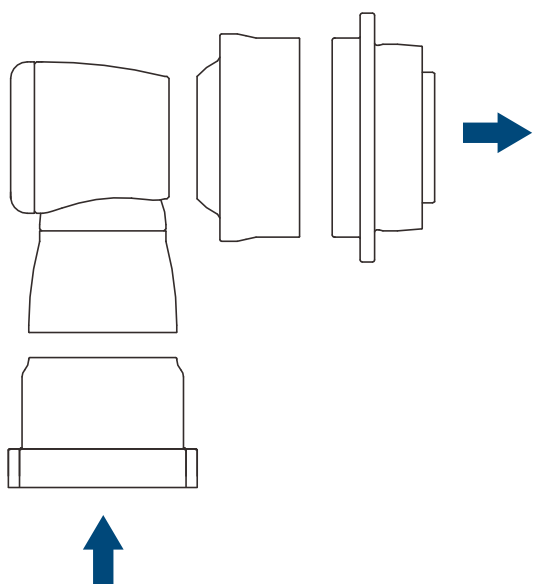

Performance - MGOHK / MGOHCK Gearbox

Model No.	Stage	Ratio ⁽¹⁾	MGOHK115 MGOHCK115	MGOHK140 MGOHCK140	MGOHK170 MGOHCK170	MGOHK240 MGOHCK240	MGOHK285 MGOHCK285	MGOHK320 MGOHCK320	
Nominal Output Torque T_{2N} By n_{1N}	2	16	240	450	840	1,800	2,015	3,935	
		20	230	435	810	1,800	2,015	3,935	
		22	245	465	780	1,740	2,685	4,815	
		27.5	245	465	785	1,750	2,700	4,840	
		28	220	415	775	1,800	1,872	3,600	
		38.5	245	470	795	1,770	2,574	4,885	
		40	192	400	740	1,725	1,728	2,880	
	55	250	475	805	1,785	2,376	3,790		
	3	64	-	380	700	1,770	2,880	5,760	
		88	-	480	815	1,800	2,185	4,970	
		100	-	370	670	1,695	2,760	5,520	
		110	-	480	820	1,810	2,800	4,990	
		137.5	-	480	825	1,820	2,815	5,020	
		140	-	370	650	1,640	2,680	5,360	
		154	-	485	825	1,825	2,820	5,035	
		160	-	380	655	1,620	2,650	5,300	
		200	-	390	665	1,585	2,600	5,200	
		220	-	490	835	1,840	2,850	5,070	
	4	280	-	400	690	1,605	2,755	5,490	
		385	-	495	850	1,845	2,890	5,130	
		400	-	390	675	1,565	2,605	5,300	
		440	-	450	835	1,840	2,840	5,060	
		500	-	400	715	1,635	2,725	5,490	
		550	-	490	845	1,860	2,870	5,110	
		700	-	455	825	1,850	3,040	5,905	
		770	-	495	850	1,870	2,895	5,150	
		1,000	-	525	810	2,100	3,395	5,815	
		1,078	-	500	860	1,890	2,920	5,180	
		1,400	-	540	845	2,220	3,430	5,815	
		1,540	-	500	870	1,910	2,945	5,220	
		1,600	-	565	845	2,225	3,435	5,760	
	2,000	-	565	810	2,240	3,455	5,815		
2,695	-	510	880	1,935	2,980	5,275			
2,800	-	540	845	2,225	3,480	5,815			
3,850	-	510	980	1,610	2,995	5,365			
4,000	-	225	650	1,840	3,515	5,815			
5,500	-	315	895	1,980	3,110	5,515			
Emergency Stop Torque T_{2NOT}	Nm	2,3,4	16~5,500						2 times T_{2N}
Max. Acceleration Torque T_{2B}	Nm	2,3,4	16~5,500						1.5 times T_{2N}
No Load Running Torque ⁽²⁾	Nm	2	16~55	1.3	2	3.1	6	13	16
		3	64~385	-	1.4	2.4	4.6	7	8.5
		4	400~5,500	-	0.2	0.3	0.6	0.9	1.2
Backlash ⁽³⁾	arcmin	2,3,4	16~5,500						≤ 4
Torsional Rigidity	Nm/arcmin	2	16~55	27	56	112	389	642	1,275
		3	64~385	-	56	112	389	642	1,275
		4	400~5,500	-	45	85	310	535	1,050
Nominal Input Speed n_{1N}	rpm	2	16~55	3,000	2,800	2,700	2,200	2,100	2,000
		3	64~385	-	3,000	2,800	2,700	2,200	2,100
		4	400~5,500	-	5,500	4,600	4,600	4,000	3,700
Max. Input Speed n_{1B}	rpm	2	16~55	6,000	6,000	4,500	4,500	4,000	3,000
		3	64~385	-	6,000	6,000	4,500	4,500	4,000
		4	400~5,500	-	7,000	7,000	7,000	6,000	5,500
Max. Axial Load F_{2a} ⁽⁴⁾	N	2,3,4	16~5,500	2,900	4,070	13,700	29,000	40,000	46,000
Max. Tilting Moment M_{2k} ⁽⁴⁾	Nm	2,3,4	16~5,500	1,300	2,180	3,600	10,500	18,400	22,000
Operating Temp.	°C	2,3,4	16~5,500						-10° C~ 90° C
Degree of Gearbox Protection		2,3,4	16~5,500						IP67
Lubrication		2,3,4	16~5,500						Lubricant
Mounting Position		2,3,4	16~5,500						All directions
Running Noise ⁽²⁾	dB(A)	2,3,4	16~5,500	≤ 68	≤ 68	≤ 68	≤ 70	≤ 70	≤ 72
Efficiency η	%	2	16~55	≥ 94%					
		3	64~385	≥ 92%					
		4	400~5,500	≥ 90%					

(1) Ratio ($i = N_{in} / N_{out}$).

(2) The values are measured by gearbox with ratio 55 (2-stage), 385 (3-stage) or ratio 5,500 (4-stage), no loading at 3,000 RPM or at the respective Nominal Input Speed by bigger model size.

By lower ratio and/or higher RPM, the values could be higher.

(3) Backlash is measured at 2% of Nominal Output Torque T_{2N} .

(4) Applied to the output flange/curvic center at 100 rpm. The calculation formula please refer to page (20)

(5) Continuous operation is not recommended.

Max. Inertia - MGOHK / MGOHCK Gearbox

Model No.		MGOHK 115 MGOHCK 115	MGOHK 140 MGOHCK 140			MGOHK 170 MGOHCK 170			MGOHK 240 MGOHCK 240			MGOHK 285 MGOHCK 285			MGOHK 320 MGOHCK 320		
Ø ^(A)	Stage	2	2	3	4	2	3	4	2	3	4	2	3	4	2	3	4
8	kg.cm ²	-	-	-	0.17	-	-	-	-	-	-	-	-	-	-	-	-
11		-	-	-	0.17	-	-	-	-	-	-	-	-	-	-	-	-
14		0.37	-	0.37	-	-	-	0.42	-	-	-	-	-	-	-	-	-
19		0.6	1.61	0.6	-	-	1.61	0.66	-	-	1.83	-	-	-	-	-	-
24		-	3.9	-	-	4.01	3.9	3.94	-	4.01	4.11	-	-	4.61	-	-	-
28		-	-	-	-	5.53	5.15	-	-	5.53	-	-	5.61	6.14	-	-	-
32		-	-	-	-	7.57	-	-	8.11	7.57	-	-	8.11	8.17	-	-	-
35		-	-	-	-	14.95	-	-	15.32	14.95	-	15.32	15.32	15.54	-	15.32	15.54
38		-	-	-	-	17.58	-	-	17.72	17.58	-	17.72	17.72	18.19	18.52	17.72	18.19
42		-	-	-	-	-	-	-	22.95	-	-	22.95	-	-	23.74	22.95	23.2
48		-	-	-	-	-	-	-	52.74	-	-	52.74	-	-	53.49	52.74	52.42
55		-	-	-	-	-	-	-	-	-	-	-	-	-	87.34	-	-

(A) Ø = Input shaft diameter.

Dimension - MGOHK (2 Stage) Gearbox (Ratio i = 16 ~ 55)

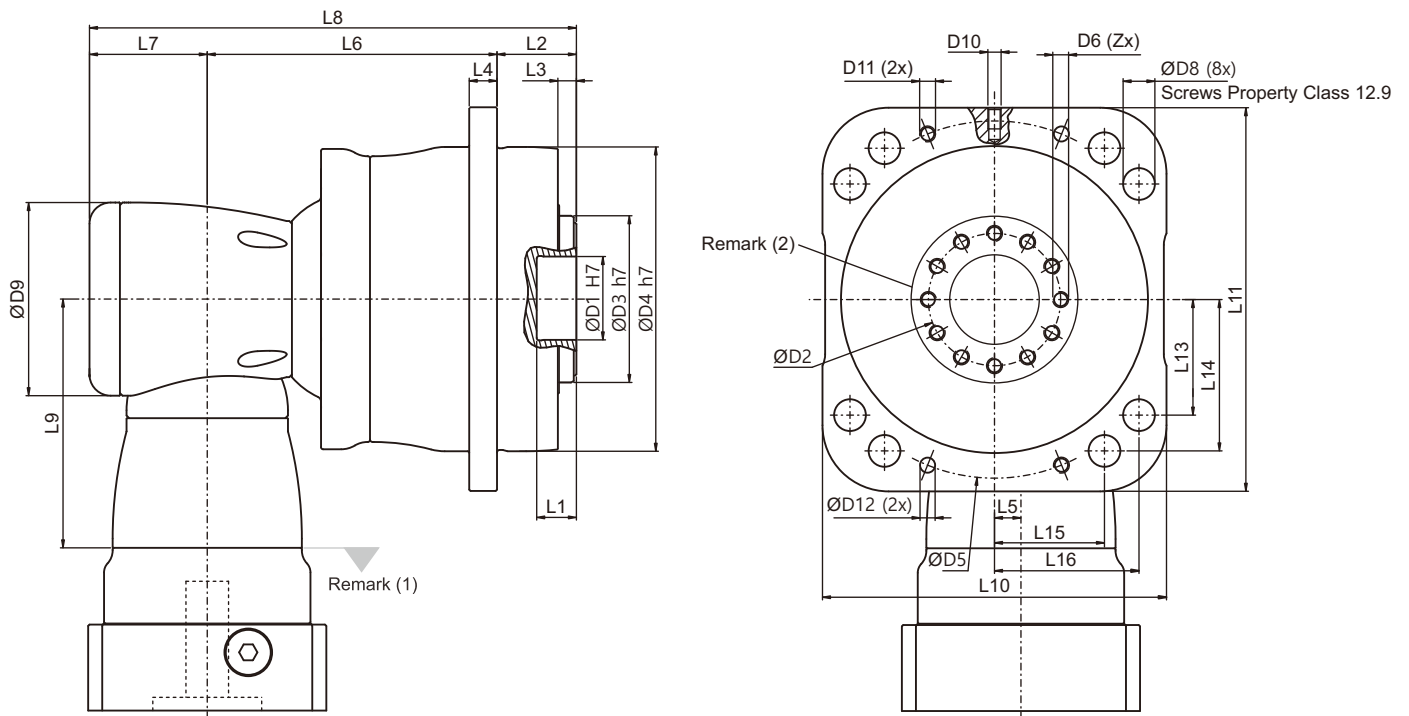

Dimension	MGOHK115	MGOHK140	MGOHK170	MGOHK240	MGOHK285	MGOHK320
D1 H7	31.5	40	50	80	100	100
D2	50	63	80	125	140	160
D3 h7	63	85	100	160	186	208
D4 h7	115	140	170	240	285	320
D5	135	167	200	276	327	368
D6 x Pitch x Deep.	M6x1Px11	M8x1.25Px12	M8x1.25Px15	M10x1.5Px20	M16x2Px25	M24x3Px37
D8	12	14	16.5	20.5	25	29
D8 Fastening Screw*	M8	M10	M12	M16	M20	M24
D10 x Pitch	M5x0.8P	M6x1P	M8x1.25P	M10x1.5P	M12x1.75P	M16x2P
D11 x Pitch	M6x1P	M8x1.25P	M10x1.5P	M12x1.75P	M16x2P	M16x2P
D12	5.7	7.7	9.7	11.7	15.7	15.7
L1	15	15	15	16	16	16
L2	30	41	48	60	70	79.9
L3	7	7	7.5	10	13.5	16.5
L4	10.5	12	15	17	22	25
L5	13	17	25	31	31	36
L6	118	120	156.5	189.9	242.8	272.9
L7	53	68.3	89	115	115	131
L8	201	229.3	293.5	364.9	427.8	483.8
L9	114.5	129	173.5	228	228	265.5
L10 h8	130	160	190	260	315	350
L11	145	180	215	280	335	390
L13	43.7	54.1	64.8	86.2	100.4	119.2
L14	57.2	70.8	84.8	111.2	132.4	154
L15	41.6	51.4	61.6	90.5	107.3	115.8
L16	54.6	67.6	80.9	113	135.5	148.9
X in Degree	30	30	22.5	22.5	24	26
Y in Degree	30	30	22.5	22.5	24	26
Z	12	12	16	16	12	12

(1) Dimensions are related to motor interface. Please contact APEX for details.

(2) Refer to the MGOH series (Page 22) for flange interface.

* Please apply the special washer provided by APEX.

Dimension - MGOHK (3 Stage) Gearbox (Ratio $i = 64 \sim 385$)

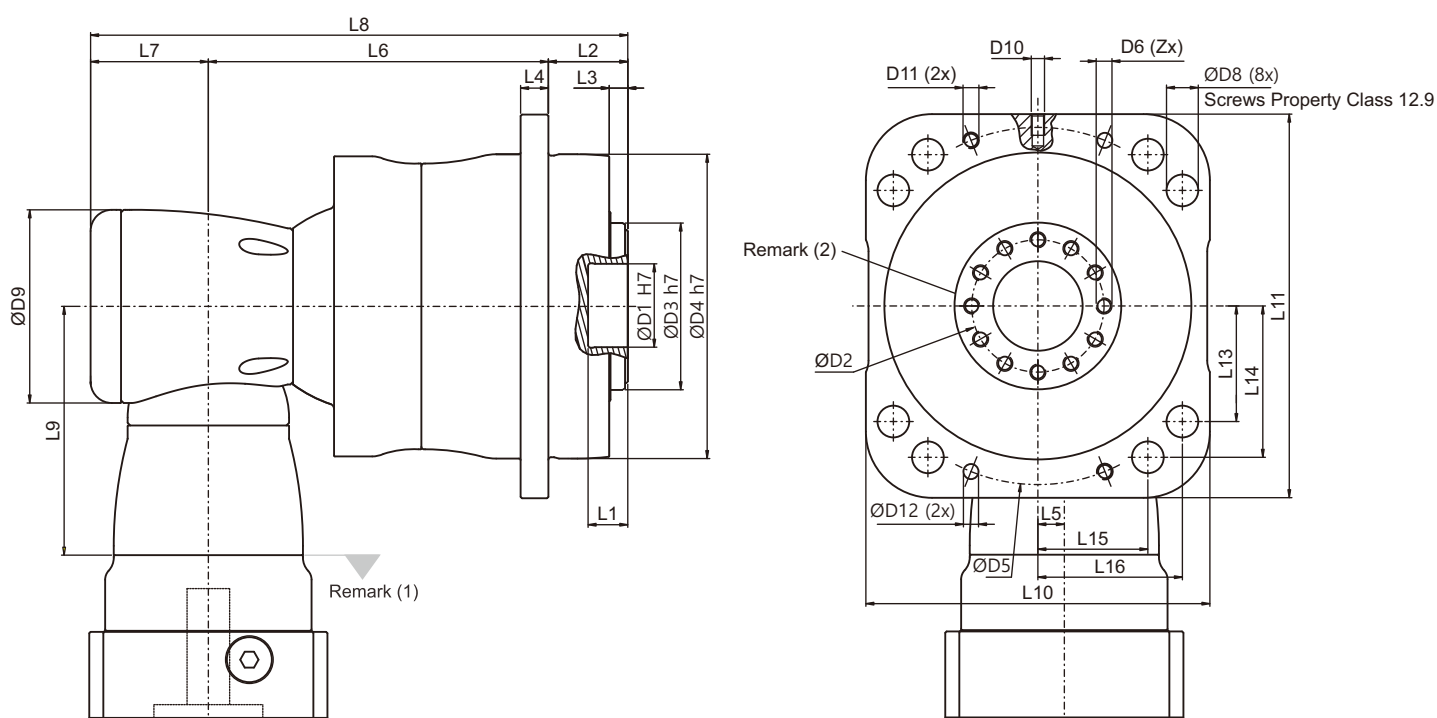

Dimension	MGOHK140	MGOHK170	MGOHK240	MGOHK285	MGOHK320
D1 H7	40	50	80	100	100
D2	63	80	125	140	160
D3 h7	85	100	160	186	208
D4 h7	140	170	240	285	320
D5	167	200	276	327	368
D6 x Pitch x Deep.	M8x1.25Px12	M8x1.25Px15	M10x1.5Px20	M16x2Px25	M24x3Px37
D8	14	16.5	20.5	25	29
D8 Fastening Screw*	M10	M12	M16	M20	M24
D9	94	116	163	210	210
D10 x Pitch	M6x1P	M8x1.25P	M10x1.5P	M12x1.75P	M16x2P
D11 x Pitch	M8x1.25P	M10x1.5P	M12x1.75P	M16x2P	M16x2P
D12	7.7	9.7	11.7	15.7	15.7
L1	15	15	16	16	16
L2	41	48	60	70	79.9
L3	7	7.5	10	13.5	16.5
L4	12	15	17	22	25
L5	13	17	25	31	31
L6	138	173	231.4	305.8	323.4
L7	53	68.3	89	115	115
L8	232	289.3	380.4	490.8	518.3
L9	114.5	129	173.5	228	228
L10 h8	160	190	260	315	350
L11	180	215	280	335	390
L13	54.1	64.8	86.2	100.4	119.2
L14	70.8	84.8	111.2	132.4	154
L15	51.4	61.6	90.5	107.3	115.8
L16	67.6	80.9	113	135.5	148.9
X in Degree	30	22.5	22.5	24	26
Y in Degree	30	22.5	22.5	24	26
Z	12	16	16	12	12

(1) Dimensions are related to motor interface. Please contact APEX for details.

(2) Refer to the MGOH series (Page 22) for flange interface.

* Please apply the special washer provided by APEX.

Dimension - MGOHK (4 Stage) Gearbox (Ratio $i = 400 \sim 5,500$)

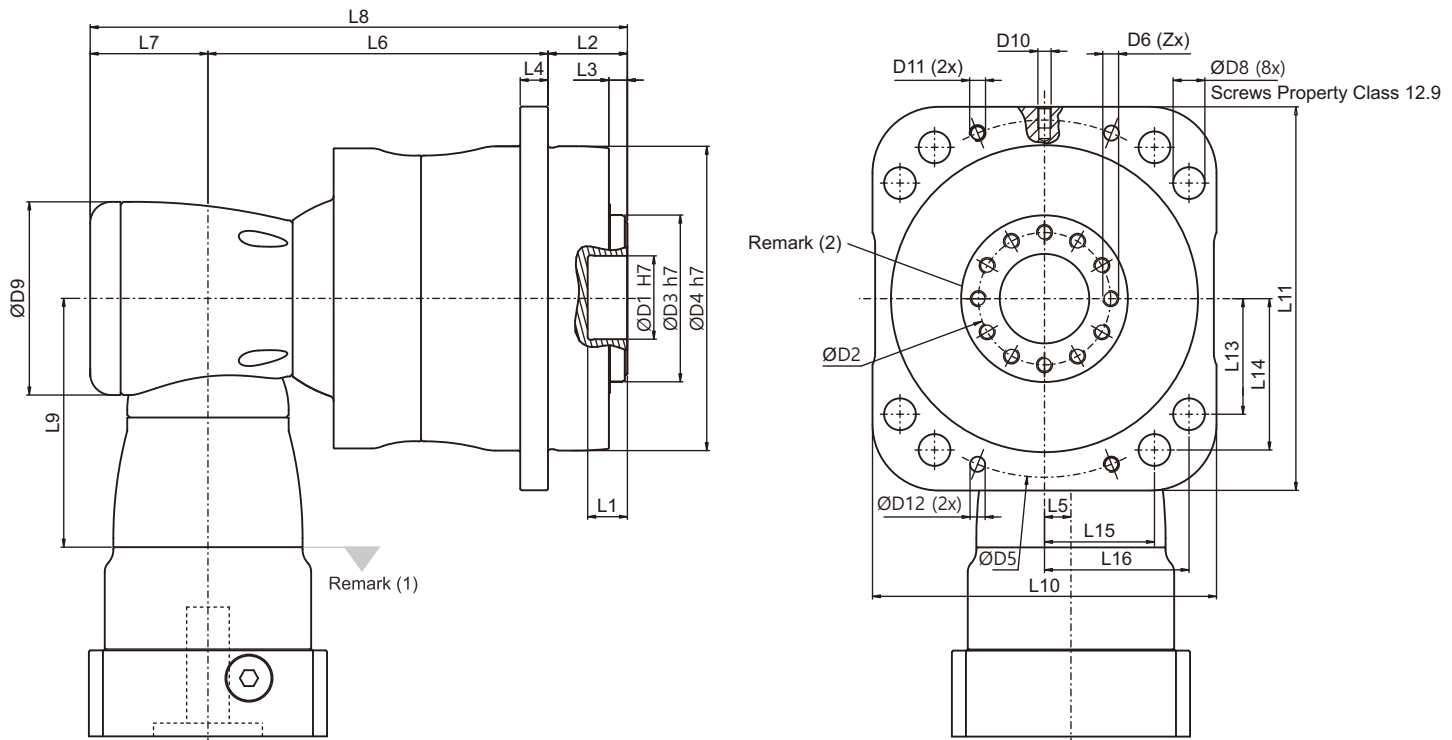

Dimension	MGOHK140	MGOHK170	MGOHK240	MGOHK285	MGOHK320
D1 H7	40	50	80	100	100
D2	63	80	125	140	160
D3 h7	85	100	160	186	208
D4 h7	140	170	240	285	320
D5	167	200	276	327	368
D6 x Pitch x Deep.	M8x1.25Px12	M8x1.25Px15	M10x1.5Px20	M16x2Px25	M24x3Px37
D8	14	16.5	20.5	25	29
D8 Fastening Screw*	M10	M12	M16	M20	M24
D9	94	116	163	210	210
D10 x Pitch	M6x1P	M8x1.25P	M10x1.5P	M12x1.75P	M16x2P
D11 x Pitch	M8x1.25P	M10x1.5P	M12x1.75P	M16x2P	M16x2P
D12	7.7	9.7	11.7	15.7	15.7
L1	15	15	16	16	16
L2	41	48	60	70	79.9
L3	7	7.5	10	13.5	16.5
L4	12	15	17	22	25
L5	13	17	25	31	31
L6	138	173	231.4	305.8	323.4
L7	53	68.3	89	115	115
L8	232	289.3	380.4	490.8	518.3
L9	114.5	129	173.5	228	228
L10 h8	160	190	260	315	350
L11	180	215	280	335	390
L13	54.1	64.8	86.2	100.4	119.2
L14	70.8	84.8	111.2	132.4	154
L15	51.4	61.6	90.5	107.3	115.8
L16	67.6	80.9	113	135.5	148.9
X in Degree	30	22.5	22.5	24	26
Y in Degree	30	22.5	22.5	24	26
Z	12	16	16	12	12

(1) Dimensions are related to motor interface. Please contact APEX for details.

(2) Refer to the MGOH series (Page 22) for flange interface.

* Please apply the special washer provided by APEX.

Dimension - MGOHCK (2 Stage) Gearbox (Ratio $i = 16 \sim 55$)

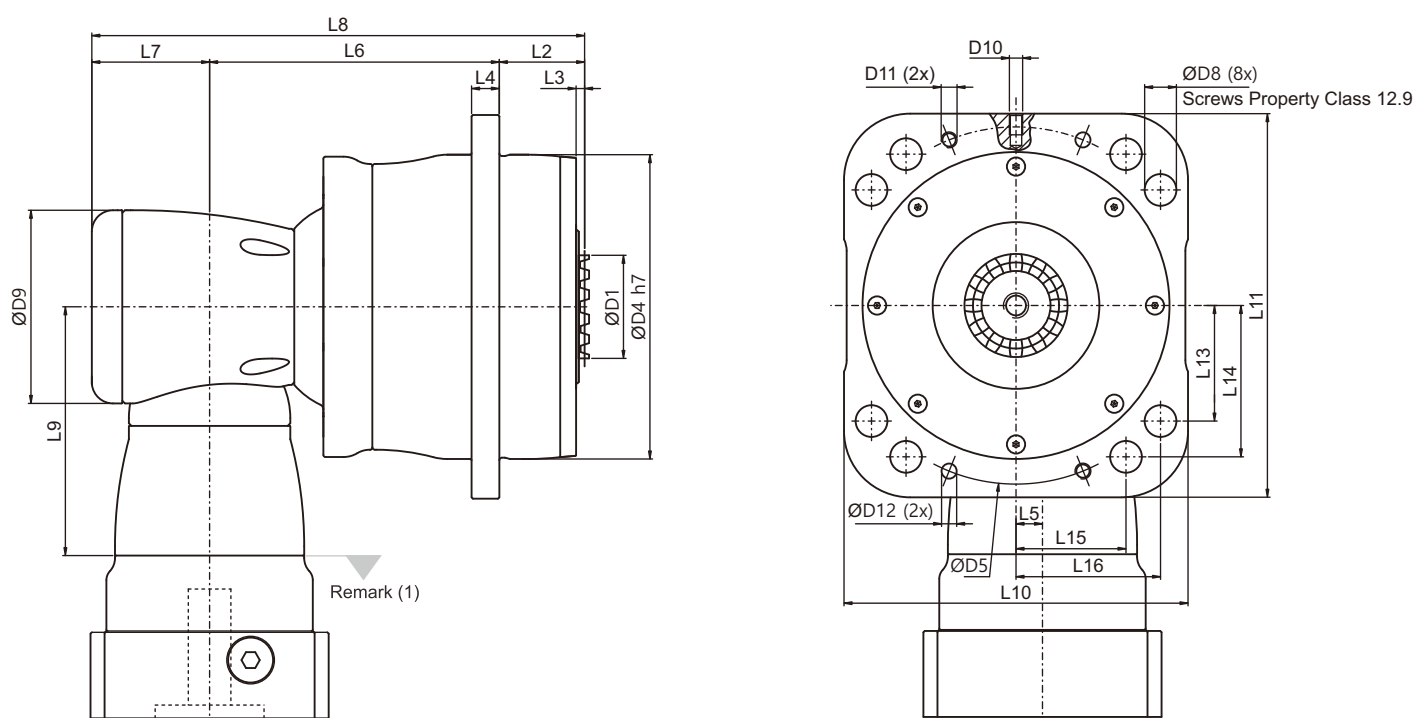

Dimension	MGOHCK115	MGOHCK140	MGOHCK170	MGOHCK240	MGOHCK285	MGOHCK320
D1	36	46	68	108	120	132
D4 h7	115	140	170	240	285	320
D5	135	167	200	276	327	368
D8	12	14	16.5	20.5	25	29
D8 Fastening Screw*	M8	M10	M12	M16	M20	M24
D9	94	116	163	210	210	255
D10 x Pitch	M5x0.8P	M6x1P	M8x1.25P	M10x1.5P	M12x1.75P	M16x2P
D11 x Pitch	M6x1P	M8x1.25P	M10x1.5P	M12x1.75P	M16x2P	M16x2P
D12	5.7	7.7	9.7	11.7	15.7	15.7
L2	32.5	46.5	54.5	70	80.5	90.4
L3	3.5	6.5	7.5	11	11.5	11.5
L4	10.5	12	15	17	22	25
L5	13	17	25	31	31	36
L6	118	120	156.5	189.9	242.8	272.9
L7	53	68.3	89	115	115	131
L8	203.5	234.8	300	374.9	438.3	494.3
L9	114.5	129	173.5	228	228	265.5
L10 h8	130	160	190	260	315	350
L11	145	180	215	280	335	390
L13	43.7	54.1	64.8	86.2	100.4	119.2
L14	57.2	70.8	84.8	111.2	132.4	154
L15	41.6	51.4	61.6	90.5	107.3	115.8
L16	54.6	67.6	80.9	113	135.5	148.9

(1) Dimensions are related to motor interface. Please contact APEX for details.

* Please apply the special washer provided by APEX.

Dimension - MGOHCK (3 Stage) Gearbox (Ratio $i = 64 \sim 385$)

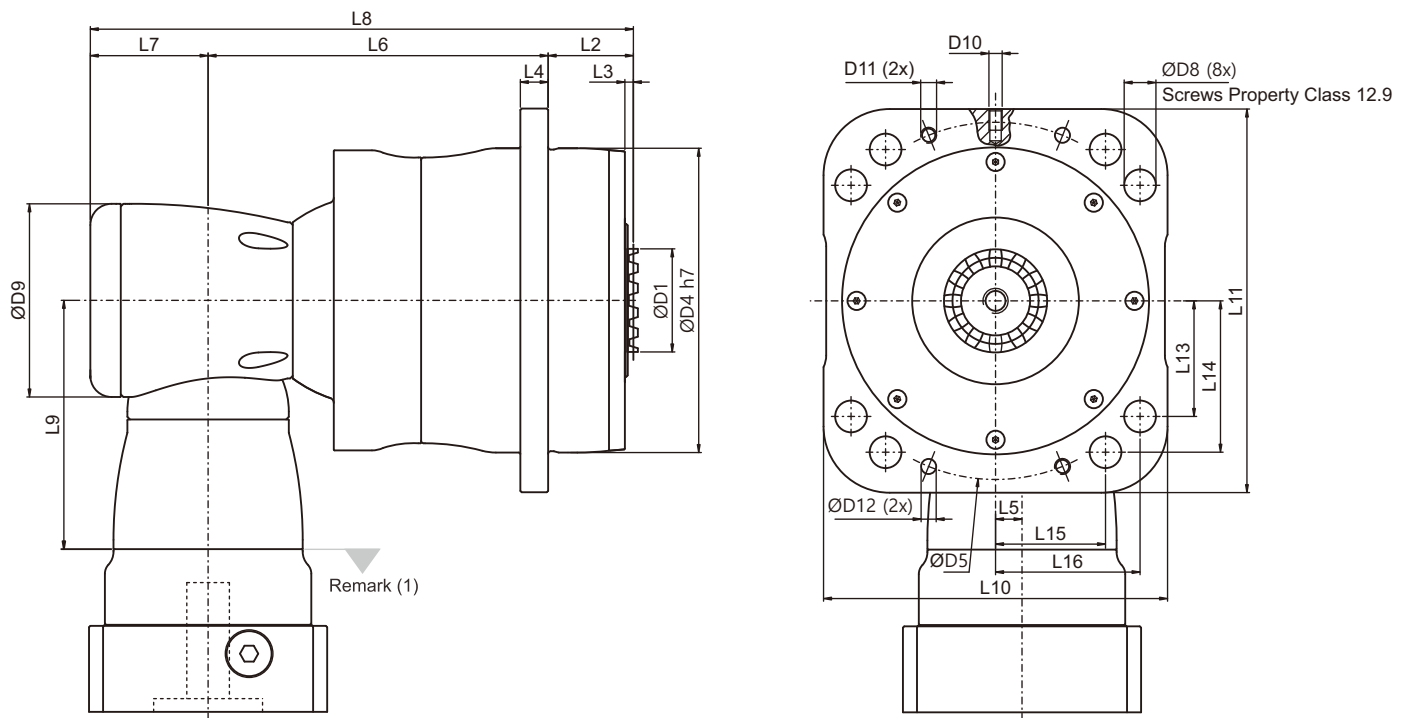

Dimension	MGOHCK140	MGOHCK170	MGOHCK240	MGOHCK285	MGOHCK320
D1	46	68	108	120	132
D4 h7	140	170	240	285	320
D5	167	200	276	327	368
D8	14	16.5	20.5	25	29
D8 Fastening Screw*	M10	M12	M16	M20	M24
D10 x Pitch	M6x1P	M8x1.25P	M10x1.5P	M12x1.75P	M16x2P
D11 x Pitch	M8x1.25P	M10x1.5P	M12x1.75P	M16x2P	M16x2P
D12	7.7	9.7	11.7	15.7	15.7
L2	46.5	54.5	70	80.5	90.4
L3	6.5	7.5	11	11.5	11.5
L4	12	15	17	22	25
L5	13	17	25	31	31
L6	138	173	231.4	305.8	323.4
L7	53	68.3	89	115	115
L8	237.5	295.8	390.4	501.3	528.8
L9	114.5	129	173.5	228	228
L10 h8	160	190	260	315	350
L11	180	215	280	335	390
L13	54.1	64.8	86.2	100.4	119.2
L14	70.8	84.8	111.2	132.4	154
L15	51.4	61.6	90.5	107.3	115.8
L16	67.6	80.9	113	135.5	148.9

(1) Dimensions are related to motor interface. Please contact APEX for details.

* Please apply the special washer provided by APEX.

Dimension - MGOHCK (4 Stage) Gearbox (Ratio $i = 400 \sim 5,500$)

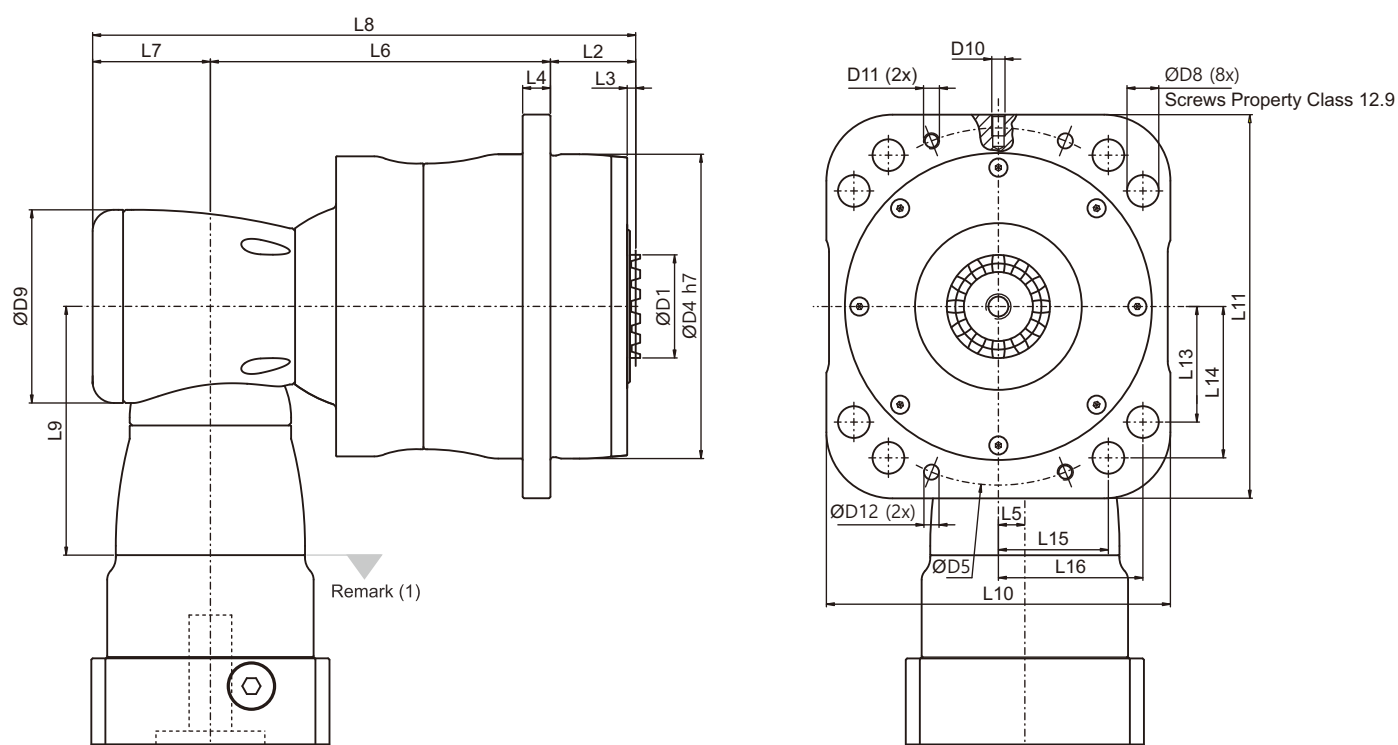

Dimension	MGOHCK140	MGOHCK170	MGOHCK240	MGOHCK285	MGOHCK320
D1	46	68	108	120	132
D4 h7	140	170	240	285	320
D5	167	200	276	327	368
D8	14	16.5	20.5	25	29
D8 Fastening Screw*	M10	M12	M16	M20	M24
D9	94	116	163	210	210
D10 x Pitch	M6x1P	M8x1.25P	M10x1.5P	M12x1.75P	M16x2P
D11 x Pitch	M8x1.25P	M10x1.5P	M12x1.75P	M16x2P	M16x2P
D12	7.7	9.7	11.7	15.7	15.7
L2	46.5	54.5	70	80.5	90.4
L3	6.5	7.5	11	11.5	11.5
L4	12	15	17	22	25
L5	13	17	25	31	31
L6	138	173	231.4	305.8	323.4
L7	53	68.3	89	115	115
L8	237.5	295.8	390.4	501.3	528.8
L9	114.5	129	173.5	228	228
L10 h8	160	190	260	315	350
L11	180	215	280	335	390
L13	54.1	64.8	86.2	100.4	119.2
L14	70.8	84.8	111.2	132.4	154
L15	51.4	61.6	90.5	107.3	115.8
L16	67.6	80.9	113	135.5	148.9

(1) Dimensions are related to motor interface. Please contact APEX for details.

* Please apply the special washer provided by APEX.

Performance - MGOHK / MGOHCK (2 Stage) Gearbox (Ratio $i = 4 \sim 11$)

Model No.		Stage	Ratio ⁽¹⁾	MGOHK115 MGOHCK115	MGOHK140 MGOHCK140	MGOHK170 MGOHCK170	MGOHK240 MGOHCK240	MGOHK285 MGOHCK285	MGOHK320 MGOHCK320
Nominal Output Torque T_{2N} By n_{1N}	Nm	2	4	75	510	845	1,728	2,805	5,545
			5.5	105	440	745	1,665	2,590	4,700
			8	150	525	845	1,584	2,610	5,680
			11	210	455	765	1,710	2,655	4,800
Emergency Stop Torque T_{2NOT}	Nm	2	4~11	2 times T_{2N}					
Max. Acceleration Torque T_{2B}	Nm	2	4~11	1.5 times T_{2N}					
No Load Running Torque ⁽²⁾	Nm	2	4~11	2.5	5.8	12	25	48	95
Backlash ⁽³⁾	arcmin	2	4~11	≤ 4					
Torsional Rigidity	Nm/arcmin	2	4~11	27	56	112	389	642	1,275
Nominal Input Speed n_{1N}	rpm	2	4~11	3,600	3,000	2,300	1,800	1,500	1,100
Max. Input Speed n_{1B}	rpm	2	4~11	6,000	5,500	4,500	3,500	3,000	2,200
Max. Axial Load F_{2a} ⁽⁴⁾	N	2	4~11	2,900	4,070	13,700	29,000	40,000	46,000
Max. Tilting Moment M_{2K} ⁽⁴⁾	Nm	2	4~11	1,300	2,180	3,600	10,500	18,400	22,000
Operating Temp.	°C	2	4~11	-10° C ~ 90° C					
Degree of Gearbox Protection		2	4~11	IP67					
Lubrication		2	4~11	Lubricant					
Mounting Position		2	4~11	All directions					
Running Noise ⁽²⁾	dB(A)	2	4~11	≤ 68	≤ 68	≤ 68	≤ 68	≤ 68	≤ 68
Efficiency η	%	2	4~11	≥ 95%					

(1) Ratio ($i = N_{in} / N_{out}$).

(2) The values are measured by gearbox with ratio 11 (2-stage), no loading at 3,000 RPM or at the respective Nominal Input Speed by bigger model size.
By lower ratio and/or higher RPM, the values could be higher.

(3) Backlash is measured at 2% of Nominal Output Torque T_{2N} .

(4) Applied to the output flange/curvic center at 100 rpm. The calculation formula please refer to page (20).

(5) Continuous operation is not recommended.

Max. Inertia - MGOHK / MGOHCK (2 Stage) Gearbox (Ratio $i = 4 \sim 11$)

Model No.		MGOHK115 MGOHCK115	MGOHK140 MGOHCK140	MGOHK170 MGOHCK170	MGOHK240 MGOHCK240	MGOHK285 MGOHCK285	MGOHK320 MGOHCK320
∅ ^(A)	Stage	2st	2st	2st	2st	2st	2st
11	kg.cm ²	0.41	-	-	-	-	-
14		0.41	-	-	-	-	-
19		1.61	1.61	-	-	-	-
24		3.9	4.01	5.61	-	-	-
28		-	5.53	5.61	-	-	-
32		-	7.57	8.11	-	-	-
35		-	14.95	15.32	15.32	-	-
38		-	17.58	17.72	17.72	-	-
42		-	-	22.95	22.95	23.74	-
48		-	-	52.74	52.74	53.49	55.14
55		-	-	-	-	87.34	89.59
60		-	-	-	-	-	113.06

(A) ∅ = Input shaft diameter.

Dimension - MGOHK (2 Stage) Gearbox (Ratio $i = 4 \sim 11$)

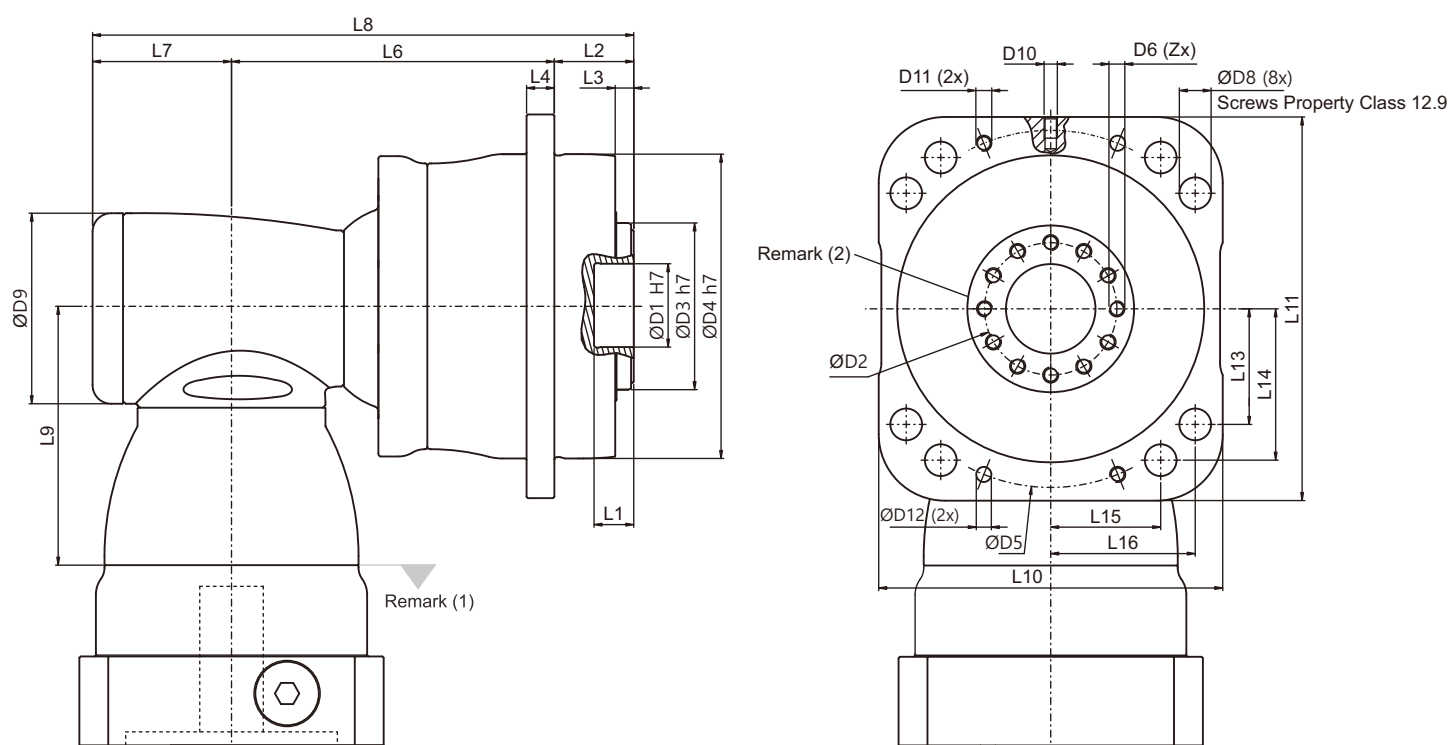

Dimension	MGOHK115	MGOHK140	MGOHK170	MGOHK240	MGOHK285	MGOHK320
D1 H7	31.5	40	50	80	100	100
D2	50	63	80	125	140	160
D3 h7	63	85	100	160	186	208
D4 h7	115	140	170	240	285	320
D5	135	167	200	276	327	368
D6 x Pitch x Deep.	M6x1Px11	M8x1.25Px12	M8x1.25Px15	M10x1.5Px20	M16x2Px25	M24x3Px37
D8	12	14	16.5	20.5	25	29
D8 Fastening Screw*	M8	M10	M12	M16	M20	M24
D9	92	116	156	156	195	240
D10 x Pitch	M5x0.8P	M6x1P	M8x1.25P	M10x1.5P	M12x1.75P	M16x2P
D11 x Pitch	M6x1P	M8x1.25P	M10x1.5P	M12x1.75P	M16x2P	M16x2P
D12	5.7	7.7	9.7	11.7	15.7	15.7
L1	15	15	15	16	16	16
L2	30	41	48	60	70	79.9
L3	7	7	7.5	10	13.5	16.5
L4	10.5	12	15	17	22	25
L6	128	130.5	184.5	199.9	250.3	228.9
L7	61.5	76	97.5	97.5	105.5	141
L8	219.5	247.5	330	357.4	425.8	509.8
L9	113.5	147.5	196.5	196.5	229	260
L10 h8	130	160	190	260	315	350
L11	145	180	215	280	335	390
L13	43.7	54.1	64.8	86.2	100.4	119.2
L14	57.2	70.8	84.8	111.2	132.4	154
L15	41.6	51.4	61.6	90.5	107.3	115.8
L16	54.6	67.6	80.9	113	135.5	148.9
X in Degree	30	30	22.5	22.5	24	26
Y in Degree	30	30	22.5	22.5	24	26
Z	12	12	16	16	12	12

(1) Dimensions are related to motor interface. Please contact APEX for details.

(2) Refer to the MGOH series (Page 22) for flange interface.

* Please apply the special washer provided by APEX.

Dimension - MGOHCK (2 Stage) Gearbox (Ratio i = 4 ~ 11)

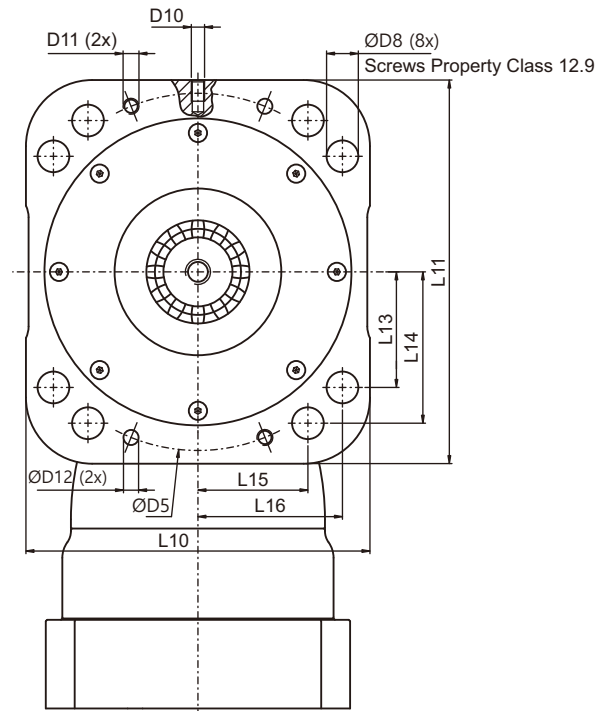
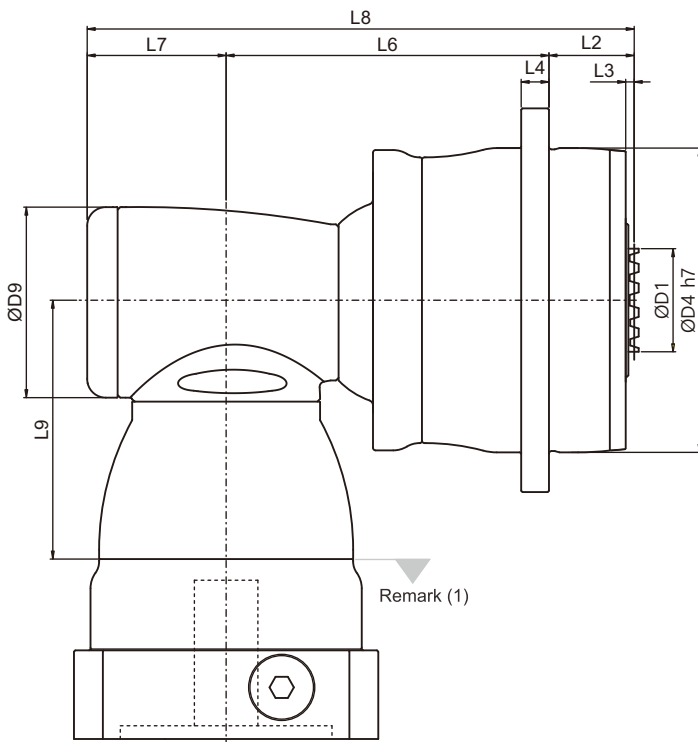

Dimension	MGOHCK115	MGOHCK140	MGOHCK170	MGOHCK240	MGOHCK285	MGOHCK320
D1	36	46	68	108	120	132
D4 h7	115	140	170	240	285	320
D5	135	167	200	276	327	368
D8	12	14	16.5	20.5	25	29
D8 Fastening Screw*	M8	M10	M12	M16	M20	M24
D9	92	116	156	156	195	240
D10 x Pitch	M5x0.8P	M6x1P	M8x1.25P	M10x1.5P	M12x1.75P	M16x2P
D11 x Pitch	M6x1P	M8x1.25P	M10x1.5P	M12x1.75P	M16x2P	M16x2P
D12	5.7	7.7	9.7	11.7	15.7	15.7
L2	32.5	46.5	54.5	70	80.5	90.4
L3	3.5	6.5	7.5	11	11.5	11.5
L4	10.5	12	15	17	22	25
L6	128	130.5	184.5	199.9	250.3	228.9
L7	61.5	76	97.5	97.5	105.5	141
L8	222	253	336.5	367.4	436.3	520.3
L9	113.5	147.5	196.5	196.5	229	260
L10 h8	130	160	190	260	315	350
L11	145	180	215	280	335	390
L13	43.7	54.1	64.8	86.2	100.4	119.2
L14	57.2	70.8	84.8	111.2	132.4	154
L15	41.6	51.4	61.6	90.5	107.3	115.8
L16	54.6	67.6	80.9	113	135.5	148.9

(1) Dimensions are related to motor interface. Please contact APEX for details.

* Please apply the special washer provided by APEX.

Rack and Pinion for MGOH series

Advantages of Curvic Coupling

- All-Teeth-Coupling between pinion and gearbox
- Zero backlash
- Automatic concentricity
- High torque transmission
- The Round-Out of the gearbox-pinion-set can be adjusted by switching the curvic positions.
- Quick assembly and disassembly or replacement
- More suitable pinion teeth-no. can be chosen, without interference with screwing.

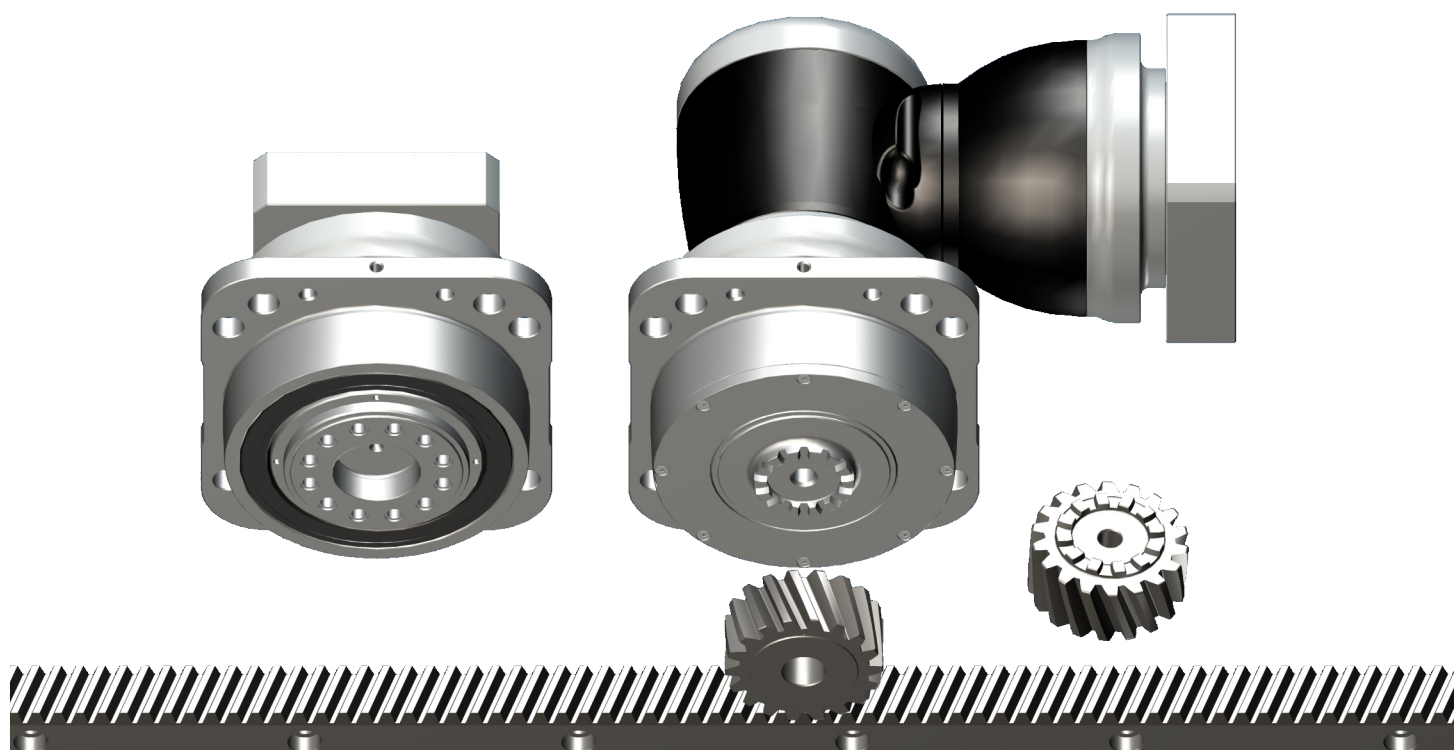
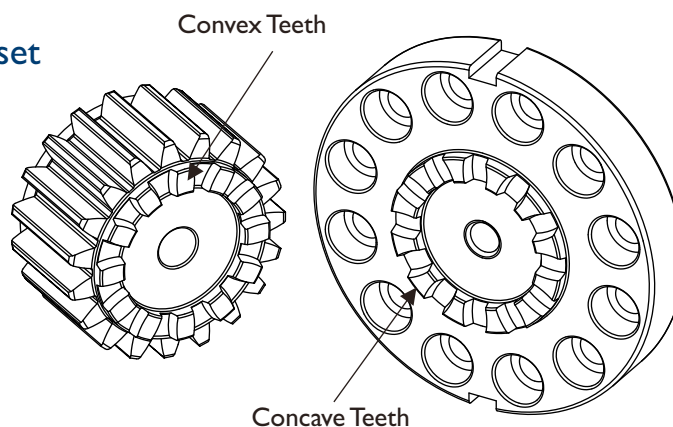

Rack with Helical Teeth

Quality 6 / Carbon Steel

Tooth Thickness Tolerance : -22 ~ 0 μm
 Right - Hand Helical
 Helical Angle β = 19° 31'42" (19.5283°)
 Pressure Angle α = 20°
 Induction Hardened and Ground
 All Sides Ground

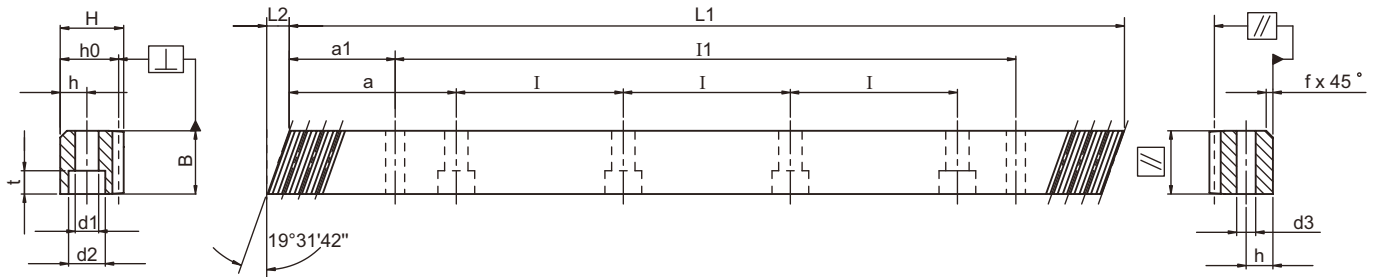

Mn	Pt ⁽¹⁾	L1	L2	Teeth No.	B	H	h0	f	a	I	Hole No.	h	d1	d2	t	a1	I1	d3	fp ⁽²⁾	Fp ⁽³⁾	Order Code
2	6.66668	500	8.5	75	24	24	22	2	62.5	125	4	8	7	11	7	31.7	436.6	5.7	0.008	0.029	0206R050C10
2	6.66668	1000	8.5	150	24	24	22	2	62.5	125	8	8	7	11	7	31.7	936.6	5.7	0.008	0.034	0206R100C10
2	6.66668	1246.67	8.5	187	24	24	22	2	62.5	125	10	8	7	11	7	31.7	1183.3	5.7	0.008	0.034	0206R125C10
2	6.66668	1500	8.5	225	24	24	22	2	62.5	125	12	8	7	11	7	31.7	1436.6	5.7	0.008	0.034	0206R150C10
2	6.66668	1746.67	8.5	262	24	24	22	2	62.5	125	14	8	7	11	7	31.7	1683.3	5.7	0.008	0.034	0206R175C10
2	6.66668	2000	8.5	300	24	24	22	2	62.5	125	16	8	7	11	7	31.7	1936.6	5.7	0.009	0.038	0206R200C10
3	10.00002	500	10.3	50	29	29	26	2	62.5	125	4	9	10	15	9	35	430	7.7	0.008	0.032	0306R050C10
3	10.00002	1000	10.3	100	29	29	26	2	62.5	125	8	9	10	15	9	35	930	7.7	0.009	0.037	0306R100C10
3	10.00002	1250	10.3	125	29	29	26	2	62.5	125	10	9	10	15	9	35	1180	7.7	0.009	0.037	0306R125C10
3	10.00002	1500	10.3	150	29	29	26	2	62.5	125	12	9	10	15	9	35	1430	7.7	0.009	0.037	0306R150C10
3	10.00002	1750	10.3	175	29	29	26	2	62.5	125	14	9	10	15	9	35	1680	7.7	0.009	0.037	0306R175C10
3	10.00002	2000	10.3	200	29	29	26	2	62.5	125	16	9	10	15	9	35	1930	7.7	0.01	0.042	0306R200C10
4	13.33335	506.67	13.8	38	39	39	35	3	62.5	125	4	12	10	15	9	33.3	433	7.7	0.009	0.034	0406R050C10
4	13.33335	506.67	13.8	38	39	39	35	3	62.5	125	4	12	14	20	13	33.3	433	11.7	0.009	0.034	0406R050CS0
4	13.33335	1000	13.8	75	39	39	35	3	62.5	125	8	12	10	15	9	33.3	933.4	7.7	0.01	0.04	0406R100C10
4	13.33335	1000	13.8	75	39	39	35	3	62.5	125	8	12	14	20	13	33.3	933.4	11.7	0.01	0.04	0406R100CS0
4	13.33335	1253.34	13.8	94	39	39	35	3	62.5	125	10	12	10	15	9	33.3	1186.7	7.7	0.01	0.04	0406R125C10
4	13.33335	1506.67	13.8	113	39	39	35	3	62.5	125	12	12	10	15	9	33.3	1433.4	7.7	0.01	0.04	0406R150C10
4	13.33335	1506.67	13.8	113	39	39	35	3	62.5	125	12	12	14	20	13	33.3	1433.4	11.7	0.01	0.04	0406R150CS0
4	13.33335	1760	13.8	132	39	39	35	3	62.5	125	14	12	10	15	9	33.3	1693.4	7.7	0.01	0.04	0406R175C10
4	13.33335	2000	13.8	150	39	39	35	3	62.5	125	16	12	10	15	9	33.3	1933.4	7.7	0.011	0.045	0406R200C10
4	13.33335	2000	13.8	150	39	39	35	3	62.5	125	16	12	14	20	13	33.3	1933.4	11.7	0.011	0.045	0406R200CS0

(1) Teeth Pitch Pt = Module x π / cos β (2) fp = Single Pitch Error (3) Fp = Total Pitch Error

Rack with Helical Teeth

Quality 6 / Carbon Steel

Tooth Thickness Tolerance : $-22 \sim 0 \mu\text{m}$

Right - Hand Helical

Helical Angle $\beta = 19^\circ 31'42'' (19.5283^\circ)$ Pressure Angle $\alpha = 20^\circ$

Induction Hardened and Ground

All Sides Ground

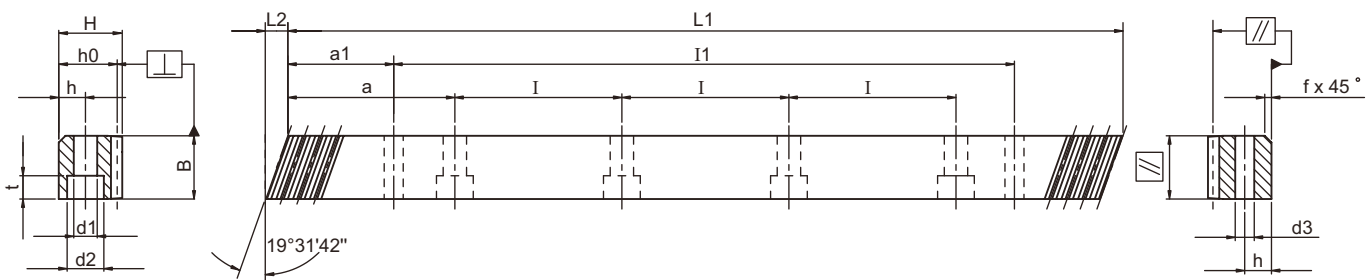

Mn	Pt ⁽¹⁾	L1	L2	Teeth No.	B	H	ho	f	a	I	Hole No.	h	d1	d2	t	a1	I1	d3	fp ⁽²⁾	Fp ⁽³⁾	Order Code
5	16.66669	500	17.4	30	49	39	34	3	62.5	125	4	12	14	20	13	37.5	425	11.7	0.009	0.034	0506R050C10
5	16.66669	1000	17.4	60	49	39	34	3	62.5	125	8	12	14	20	13	37.5	925	11.7	0.01	0.04	0506R100C10
5	16.66669	1250	17.4	75	49	39	34	3	62.5	125	10	12	14	20	13	37.5	1175	11.7	0.01	0.04	0506R125C10
5	16.66669	1500	17.4	90	49	39	34	3	62.5	125	12	12	14	20	13	37.5	1425	11.7	0.01	0.04	0506R150C10
5	16.66669	1750	17.4	105	49	39	34	3	62.5	125	14	12	14	20	13	37.5	1675	11.7	0.01	0.04	0506R175C10
5	16.66669	2000	17.4	120	49	39	34	3	62.5	125	16	12	14	20	13	37.5	1925	11.7	0.011	0.045	0506R200C10
6	20.00003	500	20.9	25	59	49	43	3	62.5	125	4	16	18	26	17	37.5	425	15.7	0.009	0.034	0606R050C10
6	20.00003	1000	20.9	50	59	49	43	3	62.5	125	8	16	18	26	17	37.5	925	15.7	0.01	0.04	0606R100C10
6	20.00003	1260	20.9	63	59	49	43	3	62.5	125	10	16	18	26	17	37.5	1185	15.7	0.01	0.04	0606R125C10
6	20.00003	1500	20.9	75	59	49	43	3	62.5	125	12	16	18	26	17	37.5	1425	15.7	0.01	0.04	0606R150C10
6	20.00003	1760	20.9	88	59	49	43	3	62.5	125	14	16	18	26	17	37.5	1685	15.7	0.01	0.04	0606R175C10
6	20.00003	2000	20.9	100	59	49	43	3	62.5	125	16	16	18	26	17	37.5	1925	15.7	0.011	0.045	0606R200C10
8	26.66671	480	28	18	79	79	71	3	60	120	4	25	22	33	21	120	240	19.7	0.011	0.037	0806R050C10
8	26.66671	960	28	36	79	79	71	3	60	120	8	25	22	33	21	120	720	19.7	0.011	0.043	0806R100C10
8	26.66671	1200	28	45	79	79	71	3	60	120	10	25	22	33	21	120	960	19.7	0.011	0.043	0806R125C10
8	26.66671	1440	28	54	79	79	71	3	60	120	12	25	22	33	21	120	1200	19.7	0.011	0.043	0806R150C10
8	26.66671	1680	28	63	79	79	71	3	60	120	14	25	22	33	21	120	1440	19.7	0.011	0.043	0806R175C10
8	26.66671	1920	28	72	79	79	71	3	60	120	16	25	22	33	21	120	1680	19.7	0.012	0.048	0806R200C10

(1) Teeth Pitch Pt = Module $\times \pi / \cos \beta$ (2) fp = Single Pitch Error (3) Fp = Total Pitch Error

Pinion with Curvic Coupling

Quality DIN4 / Alloy Steel

Tooth Thickness Tolerance : e24
 Left - Hand Helical
 Helical Angle $\beta = 19^\circ 31'42''(19.5283^\circ)$
 Pressure Angle $\alpha = 20^\circ$
 Case - Hardened and Teeth Ground

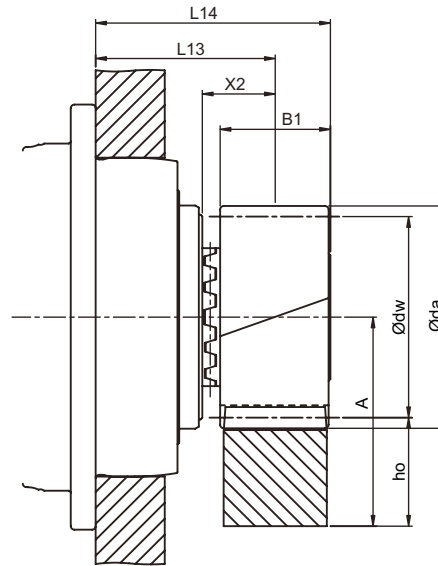

$$A = h_o + \frac{\text{Ø}dw}{2}$$

Gearbox Model	Mn	Z ⁽¹⁾	X ⁽²⁾	da ⁽³⁾	d ⁽⁴⁾	dw ⁽⁵⁾	B1	X2	L13	L14	L ⁽⁶⁾	DI ⁽⁷⁾	Order Code
MGOHC/MGOHCK 115	2	20	0.3897	48	42.441	44	26	18	48	61	133.332	36	A02L20
MGOHC/MGOHCK 140	3	20	0.3897	72	63.662	66	31	23.5	64.5	80	200	46	A03L20
MGOHC/MGOHCK 170	4	20	0.1897	94.4	84.833	86.4	41	29.5	77.5	98	266.511	68	A04L20
MGOHC/MGOHCK 240	5	23	0	132.019	122.019	122	51	38	98	123.5	383.334	108	A05L23
MGOHC/MGOHCK 285	6	23	0	158.423	146.423	146.4	61	43.5	113.5	144	460	120	A06L23
MGOHC/MGOHCK 320	8	21	0.2	197.454	178.254	181.5	81	53.5	133.4	173.9	560	132	A08L21

(1) Number of teeth (2) Profile modification factor (3) Diameter of addendum circle (4) Pitch circle diameter (5) Working pitch circle diameter

(6) Pitch circle length $L = \pi \times d$ (7) Curvic specification

Pinion material carburized surface hardness reached 60 HRC.

Teeth surface ground to reduce noise and improve wear resistance.

■ Table I. The max permitted torque and feed-force of rack and pinion.

Unit Gearbox Model	Mn	Z ⁽¹⁾	dw ⁽²⁾	F _{2T} ⁽³⁾	T _{2B} ⁽⁴⁾	M
	[mm]	[]	[mm]	[N]	[Nm]	[kg]
MGOHC/MGOHCK 115	2	20	44	8,480	180	0.33
MGOHC/MGOHCK 140	3	20	66	12,900	410	0.92
MGOHC/MGOHCK 170	4	20	86.4	22,630	960	2.12
MGOHC/MGOHCK 240	5	23	122	47,465	2,895	5.19
MGOHC/MGOHCK 285	6	23	146.4	67,610	4,950	9
MGOHC/MGOHCK 320	8	21	181.5	73,410	6,540	17.5

(1) Number of teeth (2) Working pitch circle diameter (3) Maximal Feed-Force (4) Maximal Driving Torque

- In Table I, the max. permissible torque of the curvic plate pinion and the rack is calculated under the basis of speed 3 m/s. This condition is under providing good lubrication (using the automatic lubrication system or applied grease manually every day), the tooth root strength factor $SF \geq 1.4$, teeth surface strength coefficient $SH \geq 1$, the safety factor $SB \approx 1$ and the required service life of 20,000 hours. By higher speed, the max. permissible torque reduced. The user needs to increase the safety factor for the application. Please visit APEX website (www.apexdyna.com/) for the backlash value by different center height.

Pinion with Helical Teeth (Interface : Curvic Plate / EN ISO 9409-I-A)

Quality DIN4 / Alloy Steel

Tooth Thickness Tolerance : e24
 Left - Hand Helical Teeth
 Helical Angle $\beta = 19^\circ 31'42'' (19.5283^\circ)$
 Pressure Angle $\alpha = 20^\circ$
 Case - Hardened and Teeth Ground

MGOH / MGOHK I15

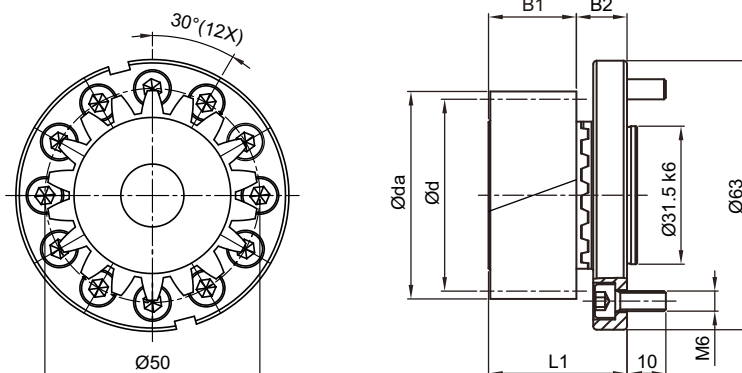

Mn	Z ⁽¹⁾	X ⁽²⁾	da ⁽³⁾	d ⁽⁴⁾	dw ⁽⁵⁾	B1	B2	L1	L ⁽⁶⁾	D1 ⁽⁷⁾	Locking screws for pinion	Order Code	
												Set	Pinion only
2	20	0.3897	48	42.441	44	26	15	41	133.334	36	M10	A02L20P050	A02L20
3	17	0.4412	62.76	54.113	56.76	31	15	46	170	36	M10	A03L17P050	A03L17

MGOH / MGOHK I40

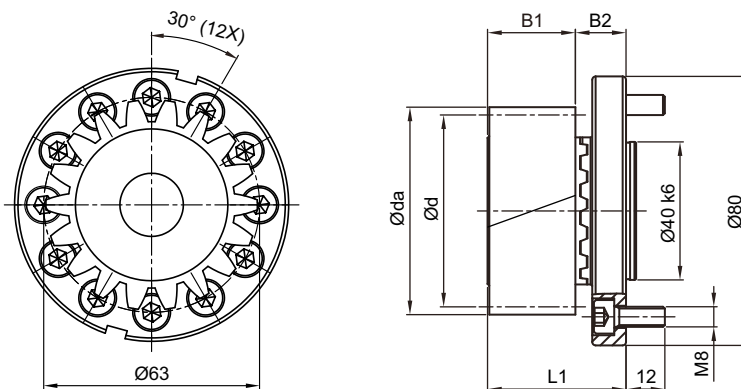

Mn	Z ⁽¹⁾	X ⁽²⁾	da ⁽³⁾	d ⁽⁴⁾	dw ⁽⁵⁾	B1	B2	L1	L ⁽⁶⁾	D1 ⁽⁷⁾	Locking screws for pinion	Order Code	
												Set	Pinion only
2	20	0.3897	48	42.441	44	26	19.5	45.5	133.334	36	M10	A02L20C063	A02L20
3	20	0.3897	72	63.662	66	31	19.5	50.5	200	46	M12	A03L20C063	A03L20

(1) Number of teeth (2) Profile modification factor (3) Diameter of addendum circle (4) Pitch circle diameter (5) Working pitch circle diameter
 (6) Pitch circle length $L = \pi \times d$ (7) Curvic specification

Pinion with Helical Teeth (Interface : Curvic Plate / EN ISO 9409-I-A)

Quality DIN4 / Alloy Steel

Tooth Thickness Tolerance : e24
 Left - Hand Helical Teeth
 Helical Angle $\beta = 19^\circ 31'42''(19.5283^\circ)$
 Pressure Angle $\alpha = 20^\circ$
 Case - Hardened and Teeth Ground

MGOH / MGOHK 170

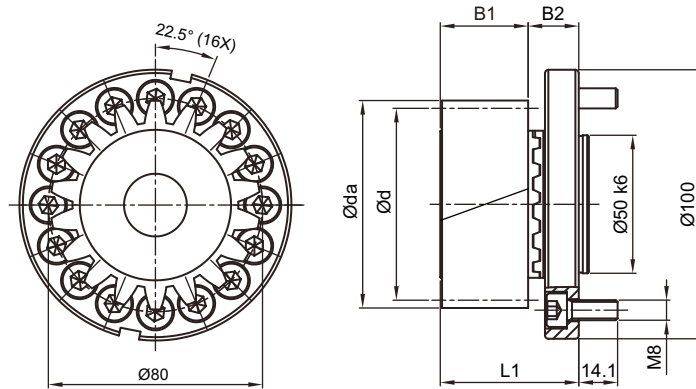

Mn	Z ⁽¹⁾	X ⁽²⁾	da ⁽³⁾	d ⁽⁴⁾	dw ⁽⁵⁾	B1	B2	L1	L ⁽⁶⁾	DI ⁽⁷⁾	Locking screws for pinion	Order Code	
												Set	Pinion only
3	18	0.1174	64	57.296	58	31	21.5	52.5	180	46	M12	A03L18P080	A03L18
	20	0.3897	72	63.662	66	31	21.5	52.5	200	46	M12	A03L20P080	A03L20
4	19	0.4102	91.92	80.639	83.92	41	21.5	62.5	253.335	60	M16	A04L19P080	A04L19

MGOH / MGOHK 240

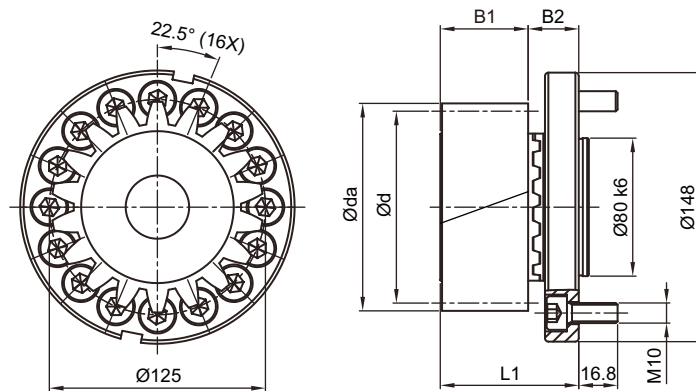

Mn	Z ⁽¹⁾	X ⁽²⁾	da ⁽³⁾	d ⁽⁴⁾	dw ⁽⁵⁾	B1	B2	L1	L ⁽⁶⁾	DI ⁽⁷⁾	Locking screws for pinion	Order Code	
												Set	Pinion only
4	18	0.6382	89.5	76.394	81.5	41	29	70	240	68	M16	A04L18P125	A04L18
	20	0.1897	94.4	84.883	86.4	41	29	70	266.667	68	M16	A04L20P125	A04L20
5	19	0.4002	114.8	100.798	104.8	51	29	80	316.666	80	M20	A05L19P125	A05L19

(1) Number of teeth (2) Profile modification factor (3) Diameter of addendum circle (4) Pitch circle diameter (5) Working pitch circle diameter (6) Pitch circle length $L = \pi \times d$ (7) Curvic specification

Pinion with Helical Teeth (Interface : Curvic Plate / EN ISO 9409-I-A)

Quality DIN4 / Alloy Steel

Tooth Thickness Tolerance : e24
 Left - Hand Helical Teeth
 Helical Angle $\beta = 19^\circ 31'42'' (19.5283^\circ)$
 Pressure Angle $\alpha = 20^\circ$
 Case - Hardened and Teeth Ground

MGOH / MGOH 285

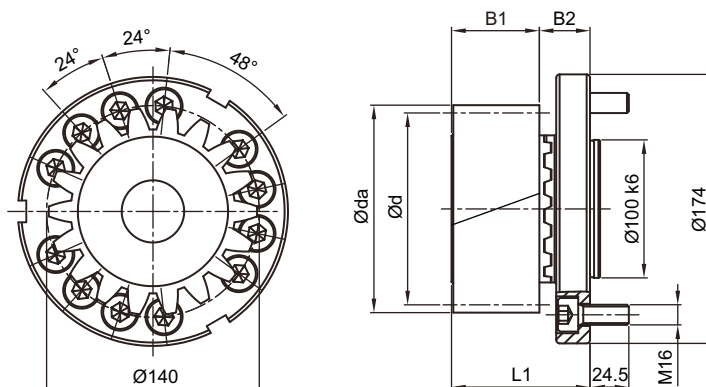

Mn	Z ⁽¹⁾	X ⁽²⁾	da ⁽³⁾	d ⁽⁴⁾	dw ⁽⁵⁾	B1	B2	L1	L ⁽⁶⁾	D1 ⁽⁷⁾	Locking screws for pinion	Order Code	
												Set	Pinion only
5	18	0.2507	108	95.493	98	51	38	89	300	80	M20	A05L18A140	A05L18
	19	0.4002	114.8	100.798	104.8	51	38	89	316.667	80	M20	A05L19A140	A05L19
6	19	0.4035	137.8	120.958	125.8	61	38	99	380	90	M24	A06L19A140	A06L19

MGOH / MGOHK 320

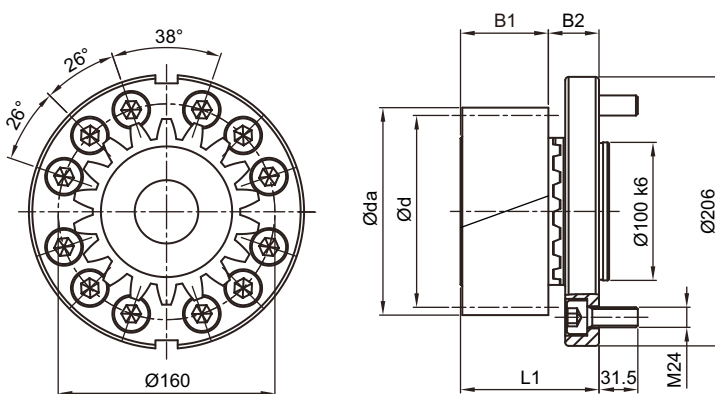

Mn	Z ⁽¹⁾	X ⁽²⁾	da ⁽³⁾	d ⁽⁴⁾	dw ⁽⁵⁾	B1	B2	L1	L ⁽⁶⁾	D1 ⁽⁷⁾	Locking screws for pinion	Order Code	
												Set	Pinion only
6	18	0.2007	129	114.592	117	61	49	110	360	90	M24	A06L18P160	A06L18
	19	0.4035	137.8	120.958	125.8	61	49	110	380	90	M24	A06L19P160	A06L19
8	19	0.4108	183.85	161.277	167.85	81	49	130	506.667	120	M30	A08L19P160	A08L19

(1) Number of teeth (2) Profile modification factor (3) Diameter of addendum circle (4) Pitch circle diameter (5) Working pitch circle diameter (6) Pitch circle length $L = \pi \times d$ (7) Curvic specification

Pinion with Helical Teeth (Interface : Curvic Plate / EN ISO 9409-I-A)

- Pinion material carburized, surface hardness reached 60 HRC.
- Teeth surface ground to reduce noise and improve wear resistance.
- Accessories include hexagon socket head cap screws (Strength 12.9 , DIN 912)
- The strength of screws is limits the max. transmission torque. Please refer to the table below :

PCD of Flange	Bolt / Screw Size	Max.Torque (Nm)
Ø50	M6 x 12 PCS	265
Ø63	M8 x 12 PCS	640
Ø80	M8 x 16 PCS	1,160
Ø125	M10 x 16 PCS	2,960
Ø140	M16 x 12 PCS	6,620
Ø160	M24 x 12 PCS	18,160

Pinion with Helical Teeth (Interface : Curvic Plate / EN ISO 9409-1-A)

- Tightening torque recommended for bolt.

Screws	Screws tightening torque(Nm)
M5 x 0.8P	9.8
M6 x 1P	17
M8 x 1.25P	41
M10 x 1.5P	80
M12 x 1.75P	139
M16 x 2P	343
M20 x 2.5P	692
M24 x 3P	1,190
M30 x 3.5P	2,380

- The maximum permissible torque of the rack

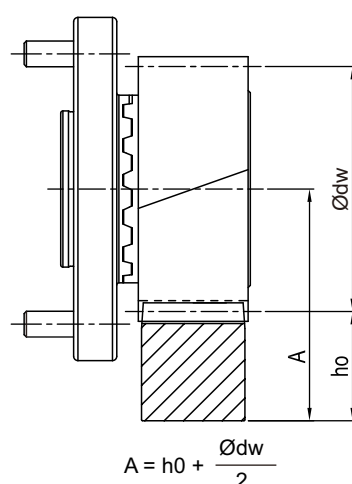

- In Table 2, the maximum permissible torque of the pinion Curvic Plate and the rack is calculated on the basis of a speed of 1.5 m/s and providing good lubrication (using an automatic lubrication system or manually applied grease every day), the tooth root strength factor $SF \geq 1.4$, tooth surface strength coefficient $SH \geq 1$, the safety factor $SB = 1$, and the required service life of 20,000 hours. By higher speed, the max. permissible torque reduced. The user needs to increase the safety factor for the application.
- Backlash changes by different center height. Please contact APEX under (WWW.APEXDYNA.COM).

■ Table 2. The max. permitted torque and feed-force of pinion Curvic Plate.

Mn [mm]	Z ⁽¹⁾ []	dw ⁽²⁾ [mm]	F _{zT} ⁽³⁾ [N]	T _{zB} ⁽⁴⁾ [Nm]
2	17	37.84	8,870	160
	20	44	8,247	175
3	17	56.76	17,741	480
	18	58	18,850	540
4	20	66	15,708	500
	18	81.5	30,761	1,175
5	19	83.92	32,119	1,295
	20	86.4	29,452	1,250
6	18	98	56,339	2,690
	19	104.8	56,549	2,850
8	18	117	77,580	4,445
	19	125.8	73,662	4,455
8	19	167.85	131,699	10,620

(1) Number of teeth (2) Working Pitch Circle Diameter (in mm) (3) Maximum Feed-Force (4) Maximum Driving Torque

Pinion with Helical Teeth (Interface : Welded Plate / EN ISO 9409-I-A)

Quality DIN4 / Alloy Steel

Tooth Thickness Tolerance : e24
 Left - Hand Helical Teeth
 Helical Angle $\beta = 19^\circ 31'42'' (19.5283^\circ)$
 Pressure Angle $\alpha = 20^\circ$
 Case - Hardened and Teeth Ground

MGOH / MGOHK I 15

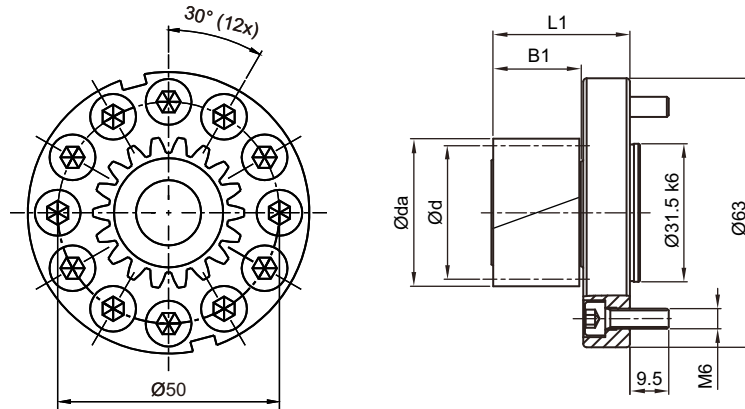

Mn	Z ⁽¹⁾	X ⁽²⁾	da ⁽³⁾	d ⁽⁴⁾	dw ⁽⁵⁾	BI	LI	L ⁽⁶⁾	Order Code
2	12	0.5	31.465	25.465	27.465	26	41	80	B02L12D050
	16	0	37.953	33.953	33.953	26	41	106.667	B02L16D050

MGOH / MGOHK I 40

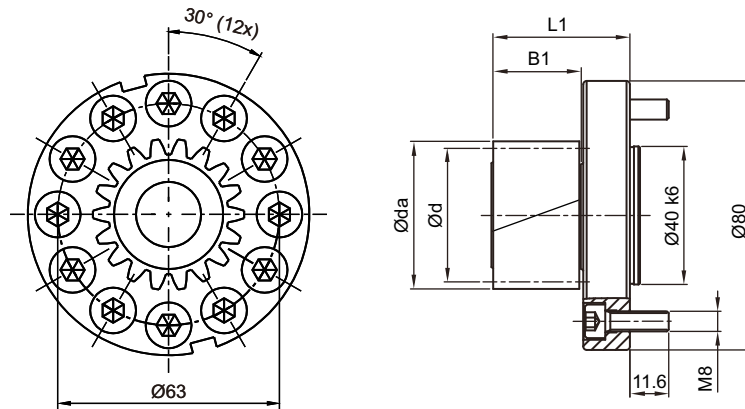

Mn	Z ⁽¹⁾	X ⁽²⁾	da ⁽³⁾	d ⁽⁴⁾	dw ⁽⁵⁾	BI	LI	L ⁽⁶⁾	Order Code
2	12	0.5	31.465	25.465	27.465	26	41	80	B02L12D063
	17	0	40.075	36.075	36.075	26	41	113.333	B02L17D063
	19	0	44.319	40.319	40.319	26	41	126.667	B02L19D063
3	12	0.5	47.197	38.197	41.197	32.5	47.5	120	B03L12D063

(1) Number of teeth (2) Profile modification factor (3) Diameter of addendum circle (4) Pitch circle diameter (5) Working pitch circle diameter (6) Pitch circle length $L = \pi \times d$

Pinion with Helical Teeth (Interface : Welded Plate / EN ISO 9409-1-A)

Quality DIN4 / Alloy Steel

Tooth Thickness Tolerance : e24
 Left - Hand Helical Teeth
 Helical Angle $\beta = 19^\circ 31'42'' (19.5283^\circ)$
 Pressure Angle $\alpha = 20^\circ$
 Case - Hardened and Teeth Ground

MGOH / MGOHK 170

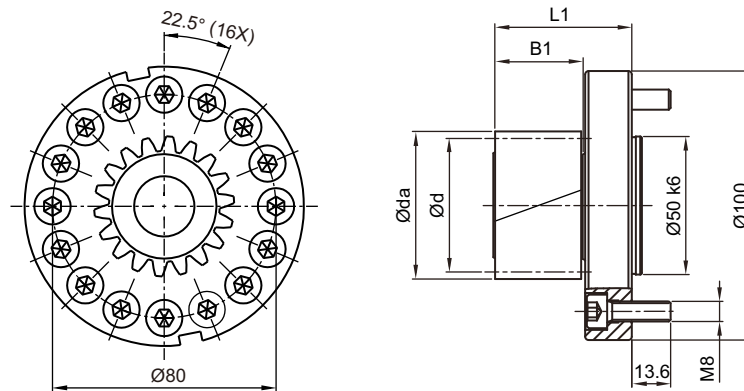

Mn	Z ⁽¹⁾	X ⁽²⁾	da ⁽³⁾	d ⁽⁴⁾	dw ⁽⁵⁾	BI	LI	L ⁽⁶⁾	Order Code
2	12	0.5	31.465	25.465	27.465	26	46	80	B02L12D080
	23	0	52.808	48.808	48.808	26	46	153.334	B02L23D080
	29	0	65.54	61.54	61.54	26	46	193.334	B02L29D080
3	12	0.5	47.197	38.197	41.197	32.5	52.5	120	B03L12D080
	16	0	56.93	50.93	50.93	32.5	52.5	160	B03L16D080
	17	0	60.113	54.113	54.113	32.5	52.5	170	B03L17D080
	19	0	66.479	60.479	60.479	32.5	52.5	190	B03L19D080
4	12	0.5	62.93	50.93	54.93	45	65	160	B04L12D080

(1) Number of teeth (2) Profile modification factor (3) Diameter of addendum circle (4) Pitch circle diameter
 (5) Working pitch circle diameter (6) Pitch circle length $L = \pi \times d$

Pinion with Helical Teeth (Interface : Welded Plate / EN ISO 9409-I-A)

Quality DIN4 / Alloy Steel

Tooth Thickness Tolerance : e24
 Left - Hand Helical Teeth
 Helical Angle $\beta = 19^\circ 31'42''(19.5283^\circ)$
 Pressure Angle $\alpha = 20^\circ$
 Case - Hardened and Teeth Ground

MGOH / MGOHK 240

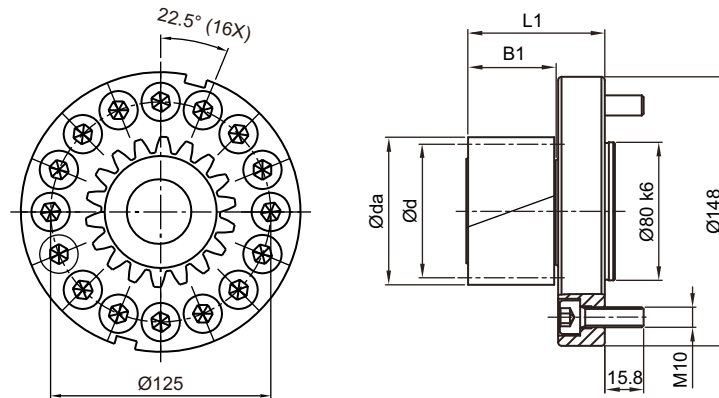

Mn	Z ⁽¹⁾	X ⁽²⁾	da ⁽³⁾	d ⁽⁴⁾	dw ⁽⁵⁾	BI	LI	L ⁽⁶⁾	Order Code
3	12	0.5	47.197	38.197	41.197	32.5	57.5	120	B03L12D125
	19	0	66.479	60.479	60.479	32.5	57.5	190	B03L19D125
	25	0	85.578	79.578	79.578	32.5	57.5	250	B03L25D125
	26	0	88.761	82.761	82.761	32.5	57.5	260	B03L26D125
	32	0	107.859	101.859	101.859	32.5	57.5	320	B03L32D125
4	12	0.5	62.93	50.93	54.93	45	70	160	B04L12D125
	15	0	71.662	63.662	63.662	45	70	200	B04L15D125
	16	0	75.906	67.906	67.906	45	70	213.334	B04L16D125
	17	0	80.15	72.15	72.15	45	70	226.667	B04L17D125
	19	0.11	89.519	80.639	81.519	45	70	253.334	B04L19D125
	20	0	92.883	84.883	84.883	45	70	266.667	B04L20D125
	23	0	105.615	97.615	97.615	45	70	306.667	B04L23D125
5	12	0.5	78.662	63.662	68.662	55	80	200	B05L12D125
	16	0	94.883	84.883	84.883	55	80	266.667	B05L16D125
	18	0	105.493	95.493	95.493	55	80	300	B05L18D125
6	12	0.5	94.394	76.394	82.394	65	90	240	B06L12D125
	13	0.5	100.761	82.761	88.761	65	90	260	B06L13D125
	15	0	107.493	95.493	95.493	65	90	300	B06L15D125

(1) Number of teeth (2) Profile modification factor (3) Diameter of addendum circle (4) Pitch circle diameter
 (5) Working pitch circle diameter (6) Pitch circle length $L = \pi \times d$

Pinion with Helical Teeth (Interface : Welded Plate / EN ISO 9409-1-A)

Quality DIN4 / Alloy Steel

Tooth Thickness Tolerance : e24
 Left - Hand Helical Teeth
 Helical Angle $\beta = 19^\circ 31'42'' (19.5283^\circ)$
 Pressure Angle $\alpha = 20^\circ$
 Case - Hardened and Teeth Ground

MGOH / MGOHK 285

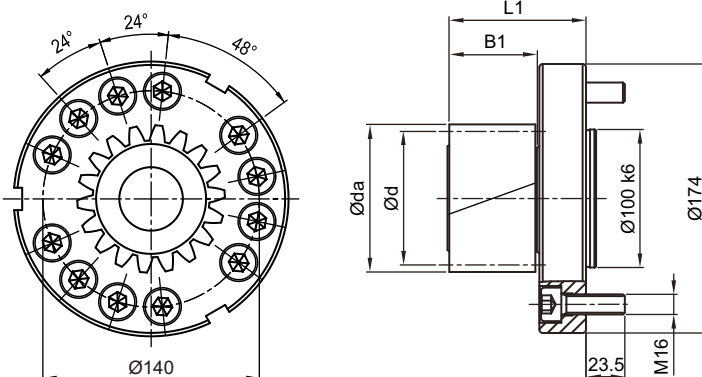

Mn	Z ⁽¹⁾	X ⁽²⁾	da ⁽³⁾	d ⁽⁴⁾	dw ⁽⁵⁾	BI	LI	L ⁽⁶⁾	Order Code
4	12	0.5	62.93	50.93	54.93	45	79	160	B04L12A140
	19	0.11	89.519	80.639	81.519	45	79	253.334	B04L19A140
	20	0	92.883	84.883	84.883	45	79	266.667	B04L20A140
5	14	0.3	87.272	74.272	77.272	55	89	233.334	B05L14A140
	18	0	105.493	95.493	95.493	55	89	300	B05L18A140
	19	0	110.798	100.798	100.798	55	89	316.667	B05L19A140
6	12	0.5	94.394	76.394	82.394	65	99	240	B06L12A140
	15	0	107.493	95.493	95.493	65	99	300	B06L15A140
	16	0	113.859	101.859	101.859	65	99	320	B06L16A140

MGOH / MGOHK 320

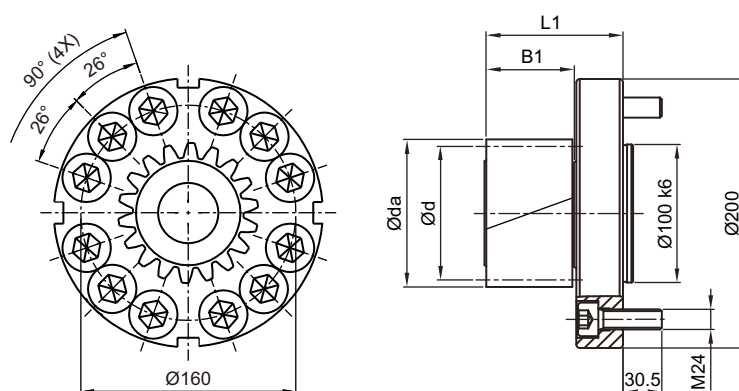

Mn	Z ⁽¹⁾	X ⁽²⁾	da ⁽³⁾	d ⁽⁴⁾	dw ⁽⁵⁾	BI	LI	L ⁽⁶⁾	Order Code
5	12	0.5	78.662	63.662	68.662	55	100	200	B05L12D160
	19	0	110.798	100.798	100.798	55	100	316.667	B05L19D160
6	12	0.5	94.394	76.394	82.394	65	110	240	B06L12D160
	16	0	113.859	101.859	101.859	65	110	320	B06L16D160

(1) Number of teeth (2) Profile modification factor (3) Diameter of addendum circle (4) Pitch circle diameter
 (5) Working pitch circle diameter (6) Pitch circle length $L = \pi \times d$

Pinion with Helical Teeth (Interface : Welded Plate / EN ISO 9409-I-A)

- Pinion material carburized, surface hardness reached 60 HRC.
- Teeth surface ground to reduce noise and improve wear resistance.
- Accessories include hexagon socket head cap screws (Strength 12.9 , DIN 912)
- The strength of screws is limits the max. transmission torque. Please refer to the table below :

PCD of Flange	Bolt / Screw Size	Max.Torque (Nm)
Ø50	M6 x 12 PCS	265
Ø63	M8 x 12 PCS	640
Ø80	M8 x 16 PCS	1,160
Ø125	M10 x 16 PCS	2,745
Ø140	M16 x 12 PCS	6,620
Ø160	M24 x 12 PCS	18,160

- Tightening torque recommended for bolt.

Screws	Screws tightening torque(Nm)
M5 x 0.8P	9.8
M6 x 1P	17
M8 x 1.25P	41
M10 x 1.5P	80
M12 x 1.75P	139
M16 x 2P	343
M20 x 2.5P	692
M24 x 3P	1,190

Pinion with Helical Teeth (Interface : Welded Plate / EN ISO 9409-1-A)

- The maximum permissible torque of the rack

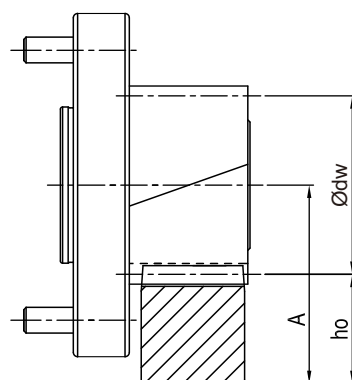

$$A = h_0 + \frac{\text{Ø}dw}{2}$$

- In Table 3, the maximum permissible torque of the pinion Welded Plate and the rack is calculated on the basis of a speed of 1.5 m/s and providing good lubrication (using an automatic lubrication system or manually applied grease every day), the tooth root strength factor $SF \cong 1.4$, tooth surface strength coefficient $SH \cong 1$, the safety factor $SB \cong 1$, and the required service life of 20,000 hours. By higher speed, the max. permissible torque reduced. The user needs to increase the safety factor for the application.
- Backlash changes by different center height. Please contact APEX under (WWW.APEXDYNA.COM).

■ Table 3. The max. permitted torque and feed-force of pinion Welded Plate.

Mn [mm]	Z⁽¹⁾ []	dw⁽²⁾ [mm]	F_{2T}⁽³⁾ [N]	T_{2B}⁽⁴⁾ [Nm]
2	12	27.465	6,283	80
	16	33.953	9,425	160
	17	36.075	9,425	170
	19	40.319	9,673	195
	23	48.808	8,810	215
	29	61.54	8,937	275
3	12	41.197	12,566	240
	16	50.93	18,850	480
	17	54.113	19,034	515
	19	60.479	19,346	585
	25	79.578	16,713	665
	26	82.761	16,675	690
4	32	101.859	16,788	855
	12	54.93	21,991	560
	15	63.662	33,772	1,075
	16	67.906	33,870	1,150
	17	72.15	35,897	1,295
	19	81.519	36,211	1,460
5	20	84.883	30,159	1,280
	23	97.615	30,323	1,480
	12	68.662	30,945	985
	14	77.272	42,142	1,565
	16	84.883	47,595	2,020
	18	95.493	55,083	2,630
6	19	100.798	55,755	2,810
	12	82.394	41,102	1,570
	13	88.761	45,191	1,870
	15	95.493	57,596	2,750
	16	101.859	62,832	3,200

(1) Number of teeth (2) Working Pitch Circle Diameter (in mm) (3) Maximum Feed-Force (4) Maximum Driving Torque

Rack with Straight Teeth

Quality 6 / Carbon Steel

Tooth Thickness Tolerance : -22 ~ 0 μm
 Straight Teeth
 Pressure Angle α = 20°
 Induction Hardened and Ground
 All Sides Ground

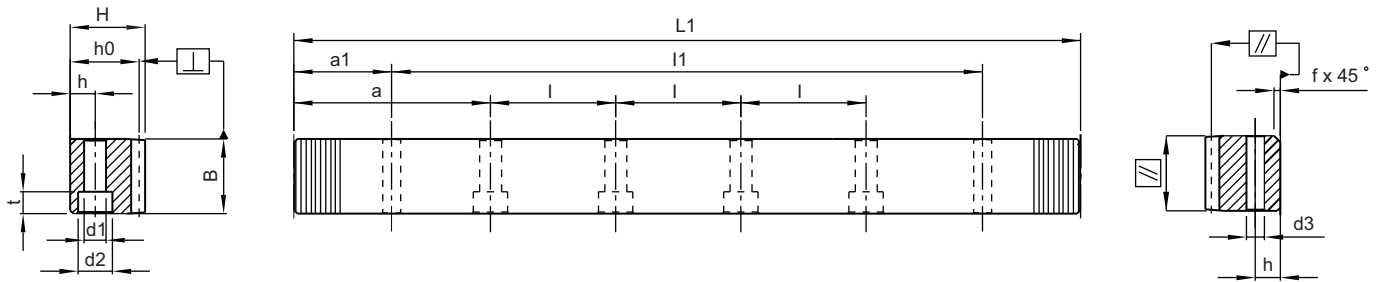

Mn	Pt ⁽¹⁾	L1	Teeth No.	B	H	ho	f	a	l	Hole No.	h	d1	d2	t	a1	l1	d3	fp ⁽²⁾	Fp ⁽³⁾	Order Code
2	6.28319	502.66	80	24	24	22	2	62.83	125.66	4	8	7	11	7	31.3	440.06	5.7	0.008	0.029	02061050C10
2	6.28319	1005.31	160	24	24	22	2	62.83	125.66	8	8	7	11	7	31.3	942.71	5.7	0.008	0.034	02061100C10
2	6.28319	1256.64	200	24	24	22	2	62.83	125.66	10	8	7	11	7	31.3	1194.04	5.7	0.008	0.034	02061125C10
2	6.28319	1507.96	240	24	24	22	2	62.83	125.66	12	8	7	11	7	31.3	1445.36	5.7	0.008	0.034	02061150C10
2	6.28319	1759.29	280	24	24	22	2	62.83	125.66	14	8	7	11	7	31.3	1696.69	5.7	0.008	0.034	02061175C10
2	6.28319	2010.62	320	24	24	22	2	62.83	125.66	16	8	7	11	7	31.3	1948.02	5.7	0.009	0.038	02061200C10
3	9.42478	508.94	54	29	29	26	2	63.62	127.23	4	9	10	15	9	34.4	440.14	7.7	0.008	0.032	03061050C10
3	9.42478	1017.88	108	29	29	26	2	63.62	127.23	8	9	10	15	9	34.4	949.08	7.7	0.009	0.037	03061100C10
3	9.42478	1272.35	135	29	29	26	2	63.62	127.23	10	9	10	15	9	34.4	1203.55	7.7	0.009	0.037	03061125C10
3	9.42478	1526.81	162	29	29	26	2	63.62	127.23	12	9	10	15	9	34.4	1458.01	7.7	0.009	0.037	03061150C10
3	9.42478	1781.28	189	29	29	26	2	63.62	127.23	14	9	10	15	9	34.4	1712.48	7.7	0.009	0.037	03061175C10
3	9.42478	2035.75	216	29	29	26	2	63.62	127.23	16	9	10	15	9	34.4	1966.952	7.7	0.01	0.042	03061200C10
4	12.56637	502.66	40	39	39	35	3	62.83	125.66	4	12	10	15	9	37.5	427.66	7.7	0.009	0.034	04061050C10
4	12.56637	502.66	40	39	39	35	3	62.83	125.66	4	12	14	20	13	37.5	427.66	11.7	0.009	0.034	04061050CS0
4	12.56637	1005.31	80	39	39	35	3	62.83	125.66	8	12	10	15	9	37.5	930.31	7.7	0.01	0.04	04061100C10
4	12.56637	1005.31	80	39	39	35	3	62.83	125.66	8	12	14	20	13	37.5	930.31	11.7	0.01	0.04	04061100CS0
4	12.56637	1256.64	100	39	39	35	3	62.83	125.66	10	12	10	15	9	37.5	1181.64	7.7	0.01	0.04	04061125C10
4	12.56637	1507.96	120	39	39	35	3	62.83	125.66	12	12	10	15	9	37.5	1432.96	7.7	0.01	0.04	04061150C10
4	12.56637	1507.96	120	39	39	35	3	62.83	125.66	12	12	14	20	13	37.5	1432.96	11.7	0.01	0.04	04061150CS0
4	12.56637	1759.29	140	39	39	35	3	62.83	125.66	14	12	10	15	9	37.5	1684.29	7.7	0.01	0.04	04061175C10
4	12.56637	2010.62	160	39	39	35	3	62.83	125.66	16	12	10	15	9	37.5	1935.62	7.7	0.011	0.045	04061200C10
4	12.56637	2010.62	160	39	39	35	3	62.83	125.66	16	12	14	20	13	37.5	1935.62	11.7	0.011	0.045	04061200CS0

(1) Teeth Pitch Pt = Module x π (2) fp = Single Pitch Error (3) Fp = Total Pitch Error

Rack with Straight Teeth

Quality 6 / Carbon Steel

Tooth Thickness Tolerance : $-22 \sim 0 \mu\text{m}$

Straight Teeth

Pressure Angle $\alpha = 20^\circ$

Induction Hardened and Ground

All Sides Ground

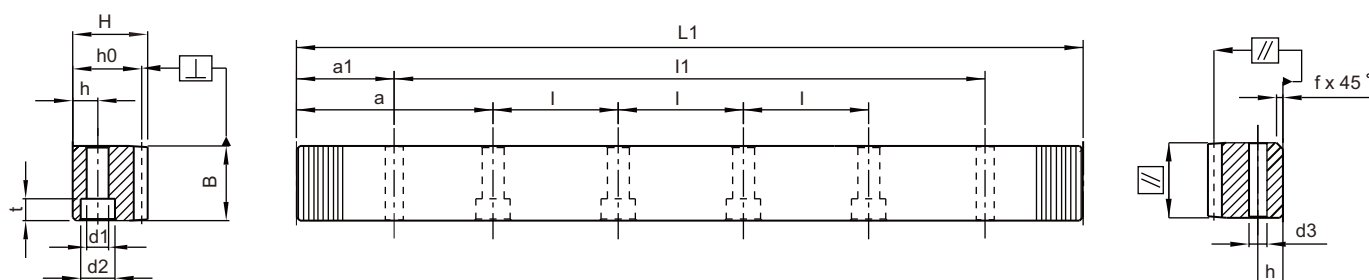

Mn	Pt ⁽¹⁾	LI	Teeth No.	B	H	ho	f	a	l	Hole No.	h	d1	d2	t	a1	l1	d3	fp ⁽²⁾	Fp ⁽³⁾	Order Code
5	15.70796	502.66	32	49	39	34	3	62.83	125.66	4	12	14	20	13	30.1	442.46	11.7	0.009	0.034	05061050C10
5	15.70796	1005.31	64	49	39	34	3	62.83	125.66	8	12	14	20	13	30.1	945.11	11.7	0.01	0.04	05061100C10
5	15.70796	1256.64	80	49	39	34	3	62.83	125.66	10	12	14	20	13	30.1	1196.44	11.7	0.01	0.04	05061125C10
5	15.70796	1507.96	96	49	39	34	3	62.83	125.66	12	12	14	20	13	30.1	1447.76	11.7	0.01	0.04	05061150C10
5	15.70796	1759.29	112	49	39	34	3	62.83	125.66	14	12	14	20	13	30.1	1699.09	11.7	0.01	0.04	05061175C10
5	15.70796	2010.62	128	49	39	34	3	62.83	125.66	16	12	14	20	13	30.1	1950.42	11.7	0.011	0.045	05061200C10
6	18.84956	508.94	27	59	49	43	3	63.62	127.23	4	16	18	26	17	31.4	446.14	15.7	0.009	0.034	06061050C10
6	18.84956	1017.88	54	59	49	43	3	63.62	127.23	8	16	18	26	17	31.4	955.08	15.7	0.01	0.04	06061100C10
6	18.84956	1281.77	68	59	49	43	3	63.62	127.23	10	16	18	26	17	31.4	1218.97	15.7	0.01	0.04	06061125C10
6	18.84956	1526.81	81	59	49	43	3	63.62	127.23	12	16	18	26	17	31.4	1464.01	15.7	0.01	0.04	06061150C10
6	18.84956	1790.71	95	59	49	43	3	63.62	127.23	14	16	18	26	17	31.4	1727.91	15.7	0.01	0.04	06061175C10
6	18.84956	2035.75	108	59	49	43	3	63.62	127.23	16	16	18	26	17	31.4	1972.95	15.7	0.011	0.045	06061200C10
8	25.13274	502.66	20	79	79	71	3	62.83	125.66	4	25	22	33	21	26.6	449.46	19.7	0.011	0.037	08061050C10
8	25.13274	1005.31	40	79	79	71	3	62.83	125.66	8	25	22	33	21	26.6	952.11	19.7	0.011	0.043	08061100C10
8	25.13274	1256.64	50	79	79	71	3	62.83	125.66	10	25	22	33	21	26.6	1203.44	19.7	0.011	0.043	08061125C10
8	25.13274	1507.96	60	79	79	71	3	62.83	125.66	12	25	22	33	21	26.6	1454.76	19.7	0.011	0.043	08061150C10
8	25.13274	1759.29	70	79	79	71	3	62.83	125.66	14	25	22	33	21	26.6	1706.09	19.7	0.011	0.043	08061175C10
8	25.13274	2010.62	80	79	79	71	3	62.83	125.66	16	25	22	33	21	26.6	1957.42	19.7	0.012	0.048	08061200C10

(1) Teeth Pitch Pt = Module $\times \pi$ (2) fp = Single Pitch Error (3) Fp = Total Pitch Error

Pinion with Curvic Coupling

Quality DIN4 / Alloy Steel

Tooth Thickness Tolerance : e24
 Straight Teeth
 Pressure Angle $\alpha = 20^\circ$
 Case - Hardened and Teeth Ground

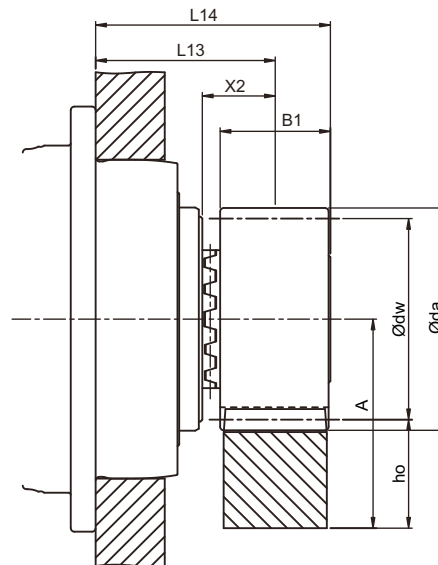

$$A = h_o + \frac{\text{Ø}dw}{2}$$

Gearbox Model	Mn	Z ⁽¹⁾	X ⁽²⁾	da ⁽³⁾	d ⁽⁴⁾	dw ⁽⁵⁾	B1	X2	L13	L14	L ⁽⁶⁾	DI ⁽⁷⁾	Order Code
MGOHC/MGOHCK 115	2	21	0.5	48	42	44	26	18	48	61	131.947	36	A02121
MGOHC/MGOHCK 140	3	21	0.5	72	63	66	31	23.5	64.5	80	197.92	46	A03121
MGOHC/MGOHCK 170	4	21	0.3	94.4	84	86.4	41	29.5	77.5	98	263.894	68	A04121
MGOHC/MGOHCK 240	5	24	0.2	132.019	120	122	51	38	98	123.5	376.991	108	A05124
MGOHC/MGOHCK 285	6	24	0.2	158.423	144	146.4	61	43.5	113.5	144	452.389	120	A06124
MGOHC/MGOHCK 320	8	22	0.3409	197.454	176	181.5	81	53.5	133.4	173.9	552.92	132	A08122

(1) Number of teeth (2) Profile modification factor (3) Diameter of addendum circle (4) Pitch circle diameter (5) Working pitch circle diameter

(6) Pitch circle length $L = \pi \times d$ (7) Curvic specification

Pinion material carburized surface hardness reached 60 HRC.

Teeth surface ground to reduce noise and improve wear resistance.

■ Table 4. The max permitted torque and feed-force of rack and pinion.

Unit Gearbox Model	Mn	Z ⁽¹⁾	dw ⁽²⁾	F _{2T} ⁽³⁾	T _{2B} ⁽⁴⁾	M
	[mm]	[]	[mm]	[N]	[Nm]	[kg]
MGOHC/MGOHCK 115	2	21	44	6,475	135	0.33
MGOHC/MGOHCK 140	3	21	66	12,380	390	0.92
MGOHC/MGOHCK 170	4	21	86.4	23,450	985	2.11
MGOHC/MGOHCK 240	5	24	122	37,830	2,270	5.19
MGOHC/MGOHCK 285	6	24	146.4	54,580	3,930	8.95
MGOHC/MGOHCK 320	8	22	181.5	82,090	7,225	17.46

(1) Number of teeth (2) Working pitch circle diameter (3) Maximal Feed-Force (4) Maximal Driving Torque

- In Table 4, the max. permissible torque of the curvic plate pinion and the rack is calculated under the basis of speed 3 m/s. This condition is under providing good lubrication (using the automatic lubrication system or applied grease manually every day), the tooth root strength factor $SF \geq 1.4$, teeth surface strength coefficient $SH \geq 1$, the safety factor $SB \approx 1$ and the required service life of 20,000 hours. By higher speed, the max. permissible torque reduced. The user needs to increase the safety factor for the application. Please visit APEX website (www.apexdyna.com/) for the backlash value by different center height.

Pinion with Straight Teeth (Interface : Curvic Plate / EN ISO 9409-I-A)

Quality DIN4 / Alloy Steel

Tooth Thickness Tolerance : e24

Straight Teeth

Pressure Angle $\alpha = 20^\circ$

Case - Hardened and Teeth Ground

MGOH / MGOHK I15

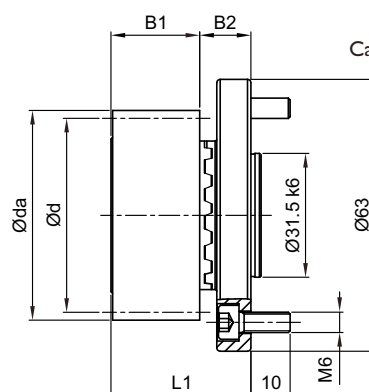
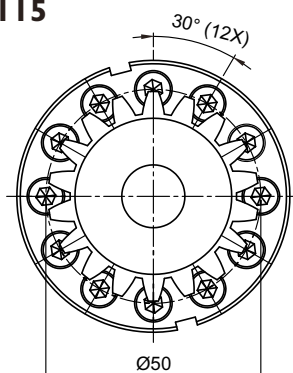

Mn	Z ⁽¹⁾	X ⁽²⁾	da ⁽³⁾	d ⁽⁴⁾	dw ⁽⁵⁾	B1	B2	L1	L ⁽⁶⁾	DI ⁽⁷⁾	Locking screws for pinion	Order Code	
												Set	Pinion only
2	21	0.5	48	42	44	26	15	41	131.947	36	M10	A02121P050	A02121

MGOH / MGOHK I40

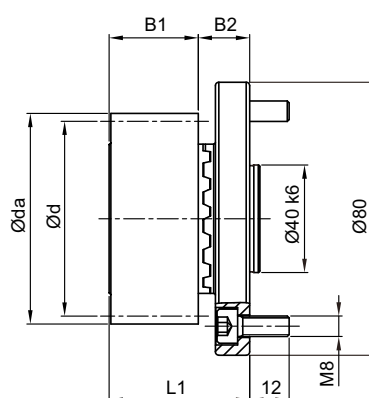
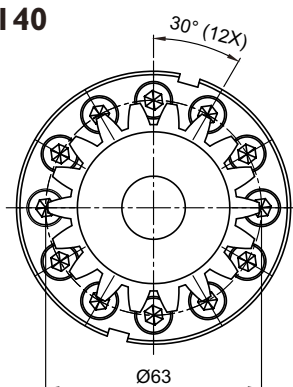

Mn	Z ⁽¹⁾	X ⁽²⁾	da ⁽³⁾	d ⁽⁴⁾	dw ⁽⁵⁾	B1	B2	L1	L ⁽⁶⁾	DI ⁽⁷⁾	Locking screws for pinion	Order Code	
												Set	Pinion only
2	21	0.5	48	42	44	26	19.5	45.5	131.947	36	M10	A02121C063	A02121

MGOH / MGOHK I70

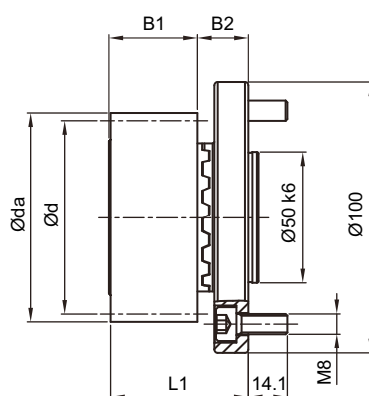
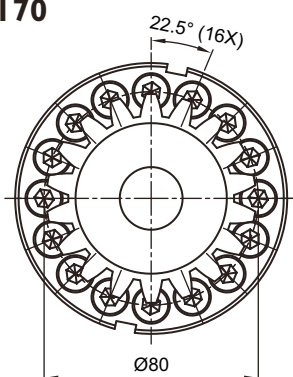

Mn	Z ⁽¹⁾	X ⁽²⁾	da ⁽³⁾	d ⁽⁴⁾	dw ⁽⁵⁾	B1	B2	L1	L ⁽⁶⁾	DI ⁽⁷⁾	Locking screws for pinion	Order Code	
												Set	Pinion only
3	19	0.1667	64	57	58	31	21.5	52.5	179.071	46	M12	A03119P080	A03119

(1) Number of teeth (2) Profile modification factor (3) Diameter of addendum circle (4) Pitch circle diameter (5) Working pitch circle diameter

(6) Pitch circle length $L = \pi \times d$ (7) Curvic specification

Pinion with Straight Teeth (Interface : Curvic Plate / EN ISO 9409-I-A)

Quality DIN4 / Alloy Steel

Tooth Thickness Tolerance : e24
 Straight Teeth
 Pressure Angle $\alpha = 20^\circ$
 Case - Hardened and Teeth Ground

MGOH / MGOHK 240

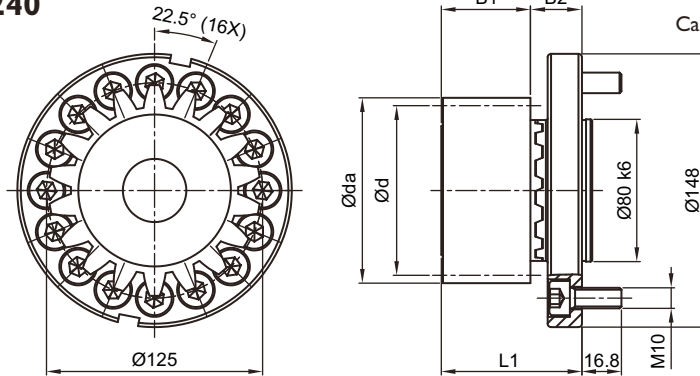

Mn	Z ⁽¹⁾	X ⁽²⁾	da ⁽³⁾	d ⁽⁴⁾	dw ⁽⁵⁾	B1	B2	L1	L ⁽⁶⁾	DI ⁽⁷⁾	Locking screws for pinion	Order Code	
												Set	Pinion only
4	19	0.6875	89.5	76	81.5	41	29	70	238.761	68	M16	A04119P125	A04119

MGOH / MGOHK 285

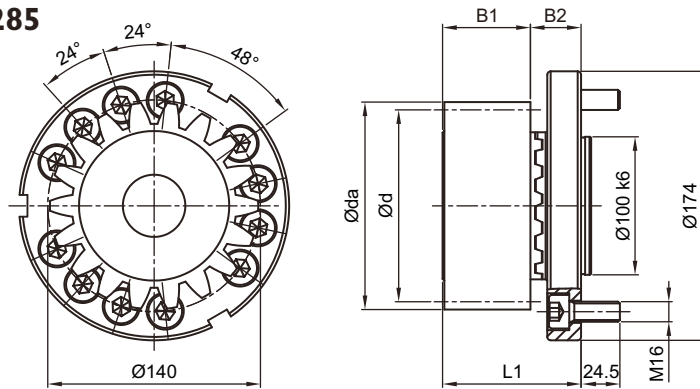

Mn	Z ⁽¹⁾	X ⁽²⁾	da ⁽³⁾	d ⁽⁴⁾	dw ⁽⁵⁾	B1	B2	L1	L ⁽⁶⁾	DI ⁽⁷⁾	Locking screws for pinion	Order Code	
												Set	Pinion only
5	19	0.3	108	95	98	51	38	89	298.451	80	M20	A05119A140	A05119

MGOH / MGOHK 320

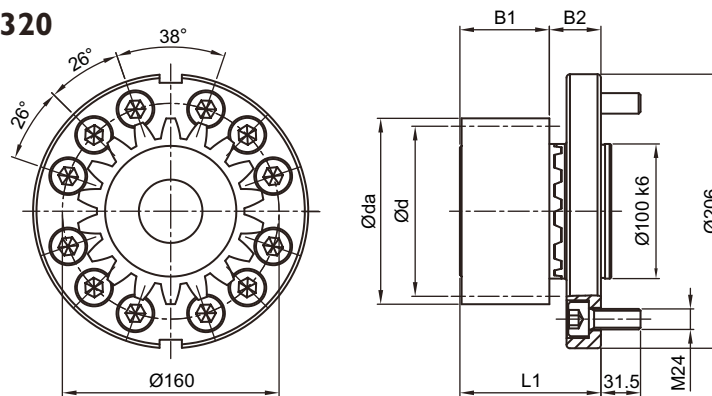

Mn	Z ⁽¹⁾	X ⁽²⁾	da ⁽³⁾	d ⁽⁴⁾	dw ⁽⁵⁾	B1	B2	L1	L ⁽⁶⁾	DI ⁽⁷⁾	Locking screws for pinion	Order Code	
												Set	Pinion only
6	19	0.25	129	114	117	61	49	110	358.142	90	M24	A06119P160	A06119

Pinion with Straight Teeth (Interface : Curvic Plate / EN ISO 9409-I-A)

- Pinion material carburized, surface hardness reached 60 HRC.
- Teeth surface ground to reduce noise and improve wear resistance.
- Accessories include hexagon socket head cap screws (Strength 12.9 , DIN 912)
- The strength of screws is limits the max. transmission torque. Please refer to the table below :

PCD of Flange	Bolt / Screw Size	Max.Torque (Nm)
Ø50	M6 x 12 PCS	265
Ø63	M8 x 12 PCS	640
Ø80	M8 x 16 PCS	1,160
Ø125	M10 x 16 PCS	2,960
Ø140	M16 x 12 PCS	6,620
Ø160	M24 x 12 PCS	18,160

- Tightening torque recommended for bolt.

Screws	Screws tightening torque(Nm)
M5 x 0.8P	9.8
M6 x 1P	17
M8 x 1.25P	41
M10 x 1.5P	80
M12 x 1.75P	139
M16 x 2P	343
M20 x 2.5P	692
M24 x 3P	1,190

- The maximum permissible torque of the rack

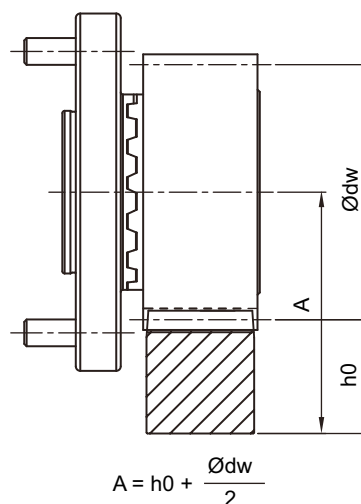
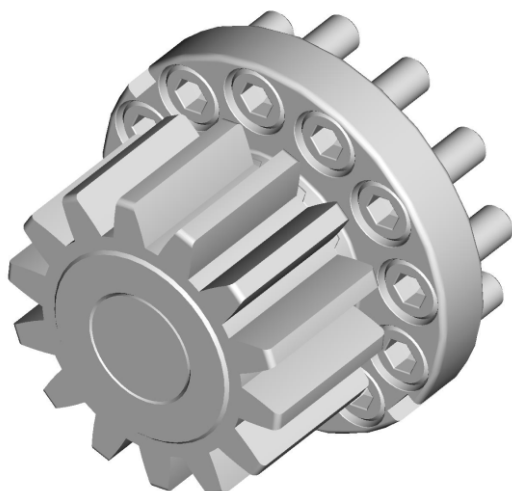

- In Table 5, the maximum permissible torque of the pinion Curvic Plate and the rack is calculated of the basis of a speed of 1.5 m/s and providing good lubrication (using an automatic lubrication system or manually applied grease every day), the tooth root strength factor $SF \cong 1.4$, tooth surface strength coefficient $SH \cong 1$, the safety factor $SB \cong 1$, and the required service life of 20,000 hours. By higher speed, the max. permissible torque reduced. The user needs to increase the safety factor for the application.
- Backlash changes by different center height. Please contact APEX under (WWW.APEXDYNA.COM).

■ Table 5. The max. permitted torque and feed-force of pinion Curvic Plate.

Mn	Z ⁽¹⁾	dw ⁽²⁾	F _{2T} ⁽³⁾	T _{2B} ⁽⁴⁾
[mm]	[]	[mm]	[N]	[Nm]
2	21	44	6,429	135
3	19	58	13,860	395
4	19	81.5	26,711	1,015
5	19	98	44,211	2,100
6	19	117	63,246	3,605

(1) Number of teeth (2) Working Pitch Circle Diameter (in mm) (3) Maximum Feed-Force (4) Maximum Driving Torque

Pinion with Straight Teeth (Interface : Welded Plate / EN ISO 9409-I-A)

Quality DIN4 / Alloy Steel

Tooth Thickness Tolerance : e24
 Straight Teeth
 Pressure Angle $\alpha = 20^\circ$
 Case - Hardened and Teeth Ground

MGOH / MGOHK I 15

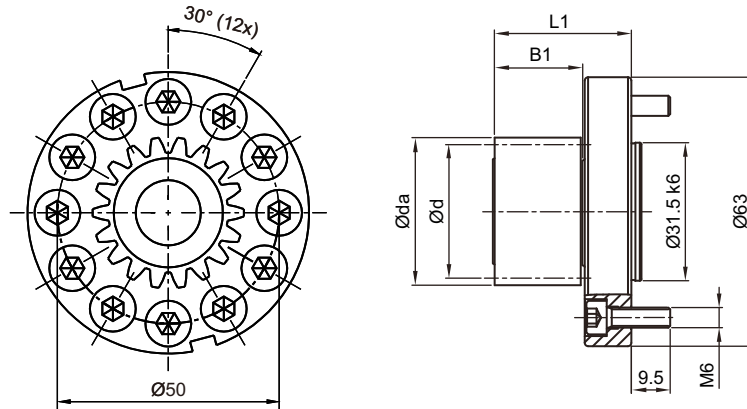

Mn	Z ⁽¹⁾	X ⁽²⁾	da ⁽³⁾	d ⁽⁴⁾	dw ⁽⁵⁾	BI	LI	L ⁽⁶⁾	Order Code
2	13	0.366	31.464	26	27.464	26	41	81.681	B02I13D050
	17	-0.012	37.952	34	33.952	26	41	106.814	B02I17D050

MGOH / MGOHK I 40

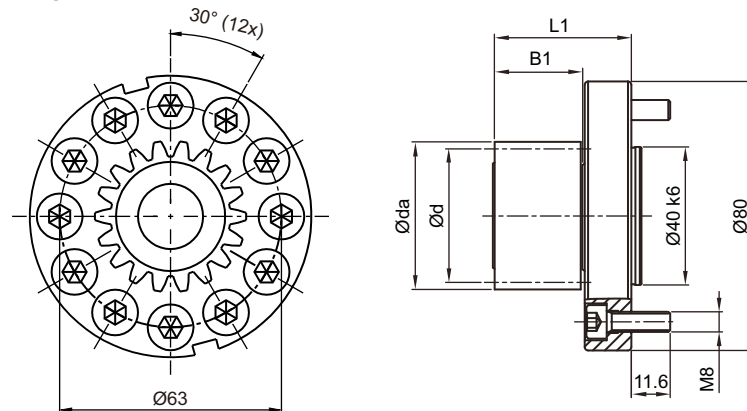

Mn	Z ⁽¹⁾	X ⁽²⁾	da ⁽³⁾	d ⁽⁴⁾	dw ⁽⁵⁾	BI	LI	L ⁽⁶⁾	Order Code
2	13	0.366	31.464	26	27.464	26	41	81.681	B02I13D063
	17	-0.012	37.952	34	33.952	26	41	106.814	B02I17D063
3	13	0.366	47.196	39	41.196	32.5	47.5	122.522	B03I13D063

(1) Number of teeth (2) Profile modification factor (3) Diameter of addendum circle (4) Pitch circle diameter
 (5) Working pitch circle diameter (6) Pitch circle length $L = \pi \times d$

Pinion with Straight Teeth (Interface : Welded Plate / EN ISO 9409-I-A)

Quality DIN4 / Alloy Steel

Tooth Thickness Tolerance : e24
 Straight Teeth
 Pressure Angle $\alpha = 20^\circ$
 Case - Hardened and Teeth Ground

MGOH / MGOHK I70

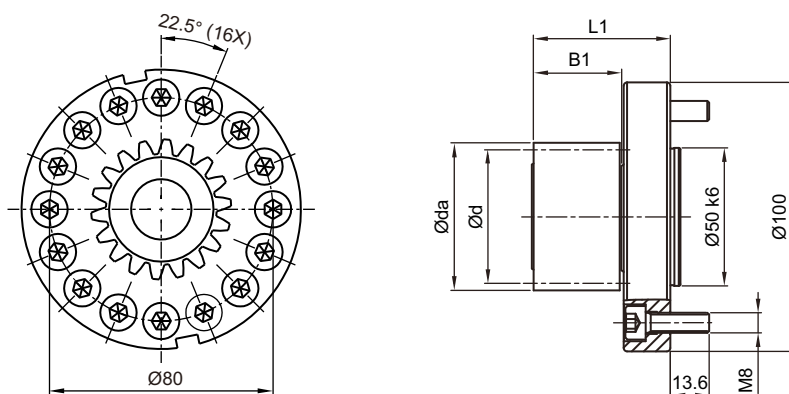

Mn	Z ⁽¹⁾	X ⁽²⁾	da ⁽³⁾	d ⁽⁴⁾	dw ⁽⁵⁾	B1	L1	L ⁽⁶⁾	Order Code
2	13	0.366	31.464	26	27.464	26	46	81.681	B02113D080
	24	0.202	52.808	48	48.808	26	46	150.796	B02124D080
3	13	0.366	47.196	39	41.196	32.5	52.5	122.522	B03113D080
	20	0.08	66.48	60	60.48	32.5	52.5	188.496	B03120D080
4	13	0.366	62.928	52	54.928	45	65	163.363	B04113D080

(1) Number of teeth (2) Profile modification factor (3) Diameter of addendum circle (4) Pitch circle diameter
 (5) Working pitch circle diameter (6) Pitch circle length $L = \pi \times d$

Pinion with Straight Teeth (Interface : Welded Plate / EN ISO 9409-I-A)

Quality DIN4 / Alloy Steel

Tooth Thickness Tolerance : e24
 Straight Teeth
 Pressure Angle $\alpha = 20^\circ$
 Case - Hardened and Teeth Ground

MGOH / MGOHK 240

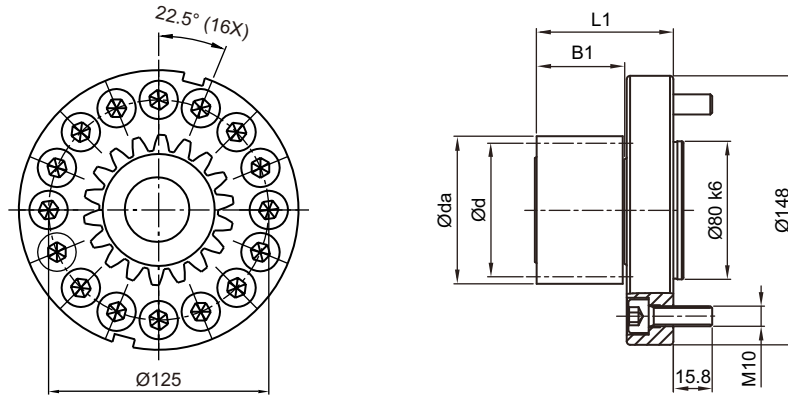

Mn	Z ⁽¹⁾	X ⁽²⁾	da ⁽³⁾	d ⁽⁴⁾	dw ⁽⁵⁾	BI	LI	L ⁽⁶⁾	Order Code
3	13	0.366	47.196	39	41.196	32.5	57.5	122.522	B03I13D125
	20	0.08	66.48	60	60.48	32.5	57.5	188.496	B03I20D125
	27	0.294	88.764	81	82.764	32.5	57.5	254.469	B03I27D125
	33	0.477	107.862	99	101.862	32.5	57.5	311.018	B03I33D125
4	13	0.366	62.928	52	54.928	45	70	163.363	B04I13D125
	20	0.19	89.52	80	81.52	45	70	251.327	B04I20D125
	21	0.11	92.88	84	84.88	45	70	263.894	B04I21D125
	24	0.202	105.616	96	97.616	45	70	301.593	B04I24D125
5	13	0.366	78.66	65	68.66	55	80	204.204	B05I13D125
	17	-0.012	94.88	85	84.88	55	80	267.035	B05I17D125
	19	0.049	105.49	95	95.49	55	80	298.451	B05I19D125
6	13	0.366	94.392	78	82.392	65	90	245.044	B06I13D125
	14	0.397	100.764	84	88.764	65	90	263.894	B06I14D125
	16	-0.042	107.496	96	95.496	65	90	301.593	B06I16D125

(1) Number of teeth (2) Profile modification factor (3) Diameter of addendum circle (4) Pitch circle diameter
 (5) Working pitch circle diameter (6) Pitch circle length $L = \pi \times d$

Pinion with Straight Teeth (Interface : Welded Plate / EN ISO 9409-I-A)

Quality DIN4 / Alloy Steel

Tooth Thickness Tolerance : e24

Straight Teeth

Pressure Angle $\alpha = 20^\circ$

Case - Hardened and Teeth Ground

MGOH / MGOHK 285

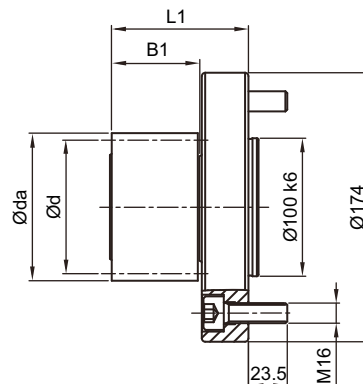
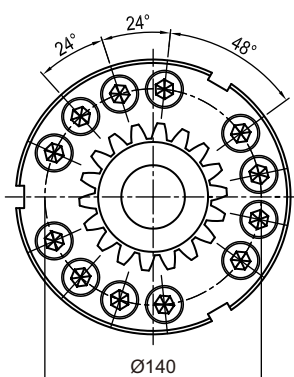

Mn	Z ⁽¹⁾	X ⁽²⁾	da ⁽³⁾	d ⁽⁴⁾	dw ⁽⁵⁾	BI	LI	L ⁽⁶⁾	Order Code
4	13	0.366	62.928	52	54.928	45	79	163.363	B04113A140
	20	0.19	89.52	80	81.52	45	79	251.327	B04120A140
	21	0.11	92.88	84	84.88	45	79	263.894	B04121A140
5	15	0.227	87.27	75	77.27	55	89	235.619	B05115A140
	20	0.08	110.8	100	100.8	55	89	314.159	B05120A140
6	13	0.366	94.392	78	82.392	65	99	245.044	B06113A140
	17	-0.012	113.856	102	101.856	65	99	320.442	B06117A140

MGOH / MGOHK 320

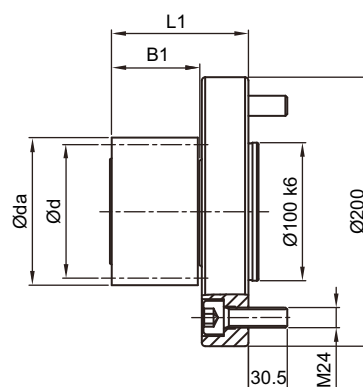
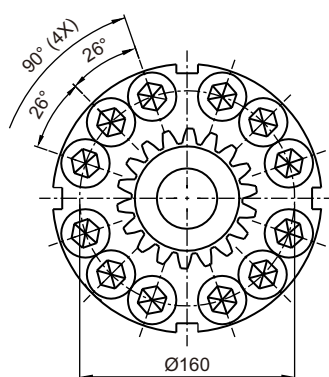

Mn	Z ⁽¹⁾	X ⁽²⁾	da ⁽³⁾	d ⁽⁴⁾	dw ⁽⁵⁾	BI	LI	L ⁽⁶⁾	Order Code
5	13	0.366	78.66	65	68.66	55	100	204.204	B05113D160
	20	0.08	110.8	100	100.8	55	100	314.159	B05120D160
6	13	0.366	94.392	78	82.392	65	110	245.044	B06113D160
	17	-0.012	113.856	102	101.856	65	110	320.442	B06117D160

(1) Number of teeth (2) Profile modification factor (3) Diameter of addendum circle (4) Pitch circle diameter
 (5) Working pitch circle diameter (6) Pitch circle length $L = \pi \times d$

Pinion with Straight Teeth (Interface : Welded Plate / EN ISO 9409-I-A)

- Pinion material carburized, surface hardness reached 60 HRC.
- Teeth surface ground to reduce noise and improve wear resistance.
- Accessories include hexagon socket head cap screws (Strength 12.9 , DIN 912)
- The strength of screws is limits the max. transmission torque. Please refer to the table below :

PCD of Flange	Bolt / Screw Size	Max.Torque (Nm)
Ø50	M6 x 12 PCS	265
Ø63	M8 x 12 PCS	640
Ø80	M8 x 16 PCS	1,160
Ø125	M10 x 16 PCS	2,745
Ø140	M16 x 12 PCS	6,620
Ø160	M24 x 12 PCS	18,160

- Tightening torque recommended for bolt.

Screws	Screws tightening torque(Nm)
M5 x 0.8P	9.8
M6 x 1P	17
M8 x 1.25P	41
M10 x 1.5P	80
M12 x 1.75P	139
M16 x 2P	343
M20 x 2.5P	692
M24 x 3P	1,190

Pinion with Straight Teeth (Interface : Welded Plate / EN ISO 9409-I-A)

- The maximum permissible torque of the rack

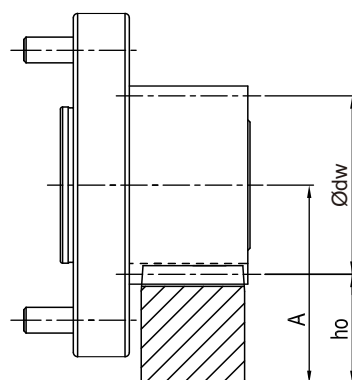

$$A = h_0 + \frac{\text{Ø}dw}{2}$$

- In Table 6, the maximum permissible torque of the pinion Welded Plate and the rack is calculated on the basis of a speed of 1.5 m/s and providing good lubrication (using an automatic lubrication system or manually applied grease every day), the tooth root strength factor $SF \cong 1.4$, tooth surface strength coefficient $SH \cong 1$, the safety factor $SB \cong 1$, and the required service life of 20,000 hours. By higher speed, the max. permissible torque reduced. The user needs to increase the safety factor for the application.
- Backlash changes by different center height. Please contact APEX under (WWW.APEXDYNA.COM).

■ Table 6. The max. permitted torque and feed-force of pinion Welded Plate.

Mn [mm]	Z⁽¹⁾ []	dw⁽²⁾ [mm]	F_{2T}⁽³⁾ [N]	T_{2B}⁽⁴⁾ [Nm]
2	13	27.264	4,231	55
	17	33.952	5,000	85
	24	48.808	6,875	165
3	13	41.196	8,462	165
	20	60.48	13,333	400
	27	82.764	13,086	530
4	33	101.862	12,828	635
	13	54.928	16,154	420
	20	81.52	24,000	960
5	21	84.88	24,286	1,020
	24	97.616	24,063	1,155
	13	68.66	25,846	840
6	15	77.27	29,867	1,120
	17	84.88	30,941	1,315
	19	95.49	38,947	1,850
6	20	100.8	38,500	1,925
	13	82.392	38,462	1,500
	14	88.764	43,929	1,845
	16	95.496	38,646	1,855
	17	101.856	45,784	2,335

(1) Number of teeth (2) Working Pitch Circle Diameter (in mm) (3) Maximum Feed-Force (4) Maximum Driving Torque

Selection of the optimum gearbox

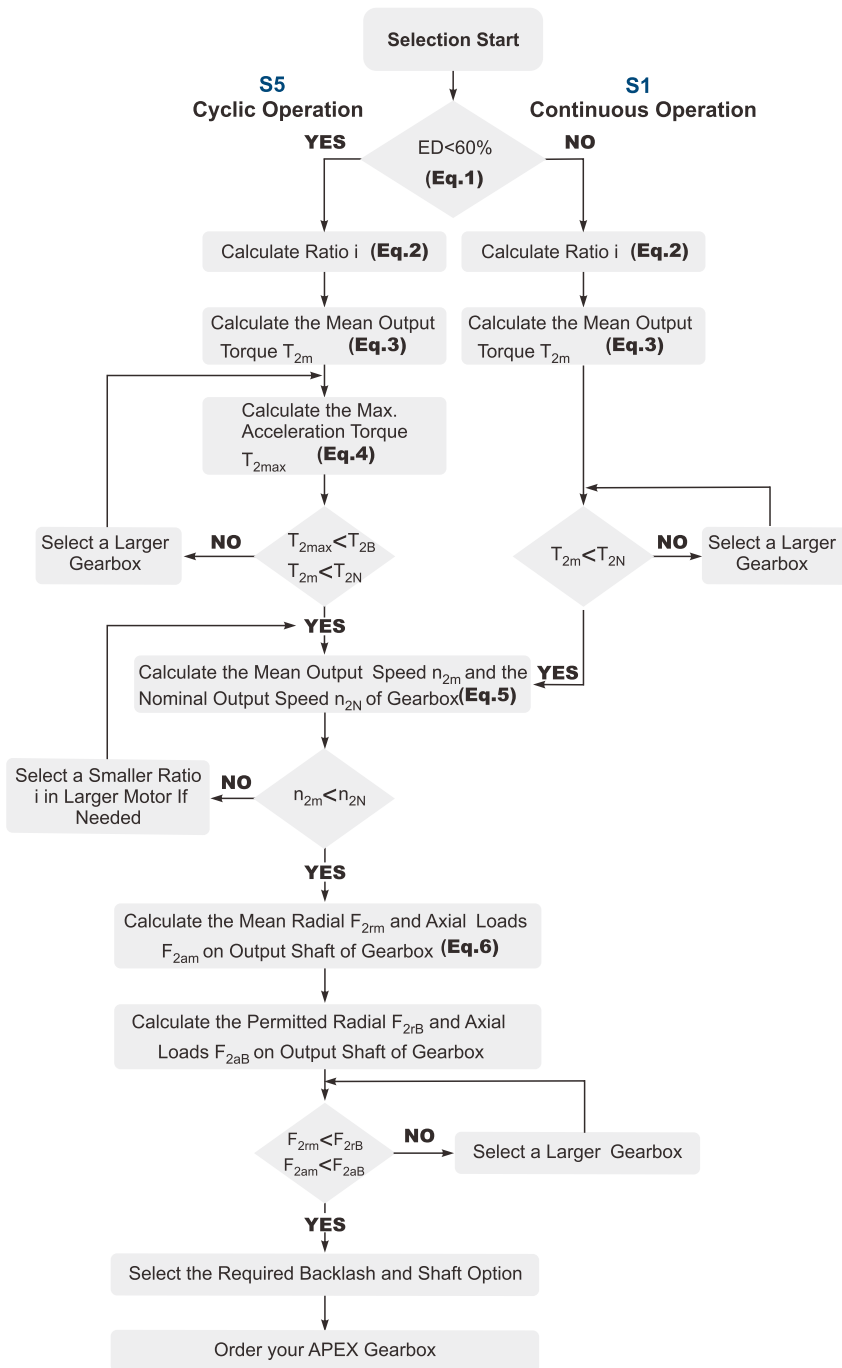

Recommended (for S5 Cycle Operation)

The general design is given for

$$\frac{J_L}{i^2} \leq 4 \times J_m$$

The optimal design is given for

$$\frac{J_L}{i^2} \cong J_m$$

J_L Load Inertia
 J_m Motor Inertia

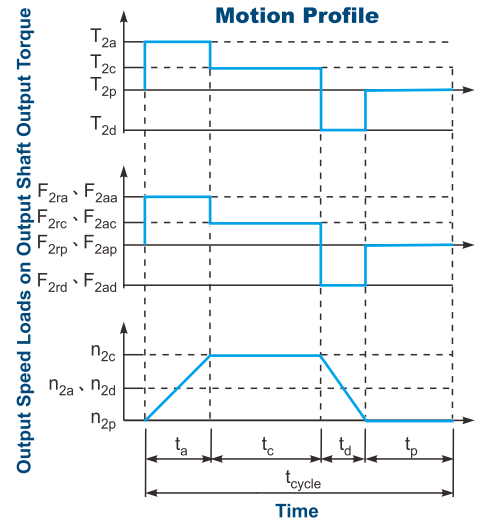

$$1. ED = \frac{t_a + t_c + t_d}{t_{cycle}} \times 100\% .$$

Index : a. Acceleration, c. Constant, d. Deceleration, p. Pause (Eq.1)

$$2. i \cong \frac{n_m}{n_{work}}$$

n_m Output Speed of the Motor
 n_{work} Working Speed (Eq.2)

$$3. T_{2m} = 3 \sqrt{\frac{n_{2a} \times t_a \times T_{2a}^3 + n_{2c} \times t_c \times T_{2c}^3 + n_{2d} \times t_d \times T_{2d}^3}{n_{2a} \times t_a + n_{2c} \times t_c + n_{2d} \times t_d}}$$

(Eq.3)

4. $T_{2max} = T_{mB} \times i \times K_s \times \eta$

where K_s is

K_s	No. of Cycles / hr
1.0	0 ~ 1,000
1.1	1,000 ~ 1,500
1.3	1,500 ~ 2,000
1.6	2,000 ~ 3,000
1.8	3,000 ~ 5,000

T_{mB} Max. Output Torque of the Motor
 η Efficiency of the Gearbox (Eq.4)

$$5. n_{2a} = n_{2d} = \frac{1}{2} \times n_{2c}$$

$$n_{2m} = \frac{n_{2a} \times t_a + n_{2c} \times t_c + n_{2d} \times t_d}{t_a + t_c + t_d}$$

$$n_{2N} = \frac{n_{1N}}{i}$$

(Eq.5)

$$6. F_{2rm} = 3 \sqrt{\frac{n_{2a} \times t_a \times F_{2ra}^3 + n_{2c} \times t_c \times F_{2rc}^3 + n_{2d} \times t_d \times F_{2rd}^3}{n_{2a} \times t_a + n_{2c} \times t_c + n_{2d} \times t_d}}$$

$$F_{2am} = 3 \sqrt{\frac{n_{2a} \times t_a \times F_{2aa}^3 + n_{2c} \times t_c \times F_{2ac}^3 + n_{2d} \times t_d \times F_{2ad}^3}{n_{2a} \times t_a + n_{2c} \times t_c + n_{2d} \times t_d}}$$

(Eq.6)

Glossary

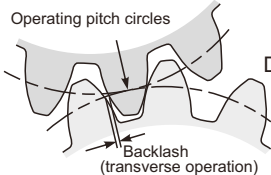
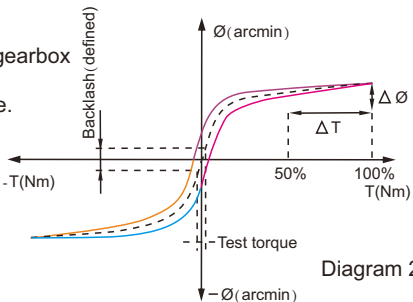
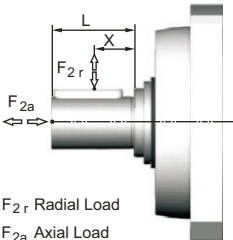
Emergency Stop Torque T_{2NOT}	Nm	The Emergency Stop Torque is the maximum permitted torque at the output of gearbox. This may happen only occasionally and may not exceed 1,000 times during the whole service life.
Max. Acceleration Torque T_{2B}	Nm	Under the Cyclic Operation (S5), the Max. Acceleration Torque is the maximum torque which can be transmitted only briefly to the output of gearbox up to 1,000 cycles/hr.
No Load Running Torque	Nm	The No Load Running Torque is the min. torque to overcome the internal friction of a gearbox without loading*.
Nominal Input Speed n_{1N}	rpm	The Nominal Input Speed is the permitted input speed of gearbox by the Continuous Operation (S1) while the housing temperature does not exceed 90°C. This value is measured at environment temperature 25°C.
Max. Input Speed n_{1B}	rpm	The Max. Input Speed is the max. permitted input speed of gearbox by the Cyclic operation (S5). This value is measured at environment temperature 25°C and serves as the absolute limit of the gearbox.
Backlash	arcmin	<p>The Backlash is the maximum angular measurement between two teeth of gears when the transverse operation occurs (refer to Diagram 1). The arcmin is the measurement unit for the backlash. One arcmin equals 1/ 60 degree, symbolized as 1'.</p>  <p style="text-align: right;">Diagram 1</p>
Torsional Rigidity	Nm/arcmin	<p>Torsional Rigidity is the quotient ($\Delta T / \Delta \theta$) between the applied torque and resulting torsion angle. This value indicates how much torque is needed on the gearbox to rotate the output shaft for 1 arcmin. The Torsional Rigidity can be determined by Hysteresis Curve.</p> <p>Hysteresis Curve When the input shaft is locked, increase torque at the output slowly up to T_{2B} in both directions and then release the torque gradually. According to the measured torque and torsion angle, a closed curve will be acquired as in the Diagram 2.</p>  <p style="text-align: right;">Diagram 2</p>
Radial Load And Axial Load	N	<p>The permitted radial and axial loads on output shaft of the gearbox depend on the design of the gearbox supporting bearings.</p> <p>For more information, please refer to APEX website.</p>  <p style="text-align: right;">F_{2r} Radial Load F_{2a} Axial Load</p>
Efficiency η	%	The transmission efficiency of the gears inside a gearbox (without friction).
Operating Temperature	°C	The Operating Temperature indicates the temperature of gearbox housing.
Degree of Protection		IP code stands for International Protection standard. The IP67 as example: the first IP number stands for protection degree against dust; the second IP number stands for protection against liquid.
Lubrication		APEX uses synthetic lubrication grease. Alternate greases are available, please contact APEX.
Running Noise	dB(A)	The Running Noise is measured depends on gearbox size, the ratio and the speed*. Higher speed usually induces higher noise level, while higher ratio induces lower noise level.
Moment of Inertia J_1	kg.cm ²	The Moment of Inertia J_1 is a measurement of the effort applied to an object to maintain its momentary condition at rest or rotating.
Breakaway Torque	Nm	The Breakaway Torque is the minimum torque to start the rotation from the input side of gearbox. A smaller size or a higher ratio gearbox requests less Breakaway Torque.
Back Driving Torque	Nm	The Back Driving Torque is the minimum torque to start the rotation from the output side of gearbox. A larger size or a higher ratio gearbox requires greater Back Driving Torque.

* This value is measured at environment temperature 25°C and the input speed 3,000 rpm. If the Nominal Input Speed n_{1N} of gearbox is lower than 3,000 rpm, this value is measured by that specific Nominal Input Speed.

Liability Disclaimer:

APEX DYNAMICS, INC. endeavors to ensure the accuracy and reliability of the data in catalog.

APEX accepts no liability, whether in any form, for any loss or damage arising from any inaccuracy or omissions of this catalog.



**APEX TAIWAN NORTH
ANDTEK AUTOMATION CO.,LTD**
TEL +886-02-82262655
13F-5, NO.2, Jian 8th Rd., Jhonghe Dist., New
Taipei City 235, TAIWAN
sales@andtek.com.tw
www.apexdyan.com



**APEX TAIWAN CENTRAL
ANDTEK AUTOMATION CO.,LTD**
TEL +886-04-23594286
9F-6, NO.925, Sec.4, Taiwan Blvd., Xitun Dist.
Taichung City 407, TAIWAN
sales@andtek.com.tw
www.apexdyan.com



**APEX TAIWAN SOUTH
MEN JENN ELECTRIC CO., LTD.**
TEL +886-06-2337332*6
NO.774, Zhonghua Rd., Yongkang Dist., Tainan
City 710, TAIWAN
menjenn@ms24.hinet.net
www.apexdyan.com



APEX TAIWAN INC. SHANGHAI
TEL +86-21-69220577
NO.128 ZHUYING Road QINGPU Industry Area,
Shanghai, CHINA
sales@apexdyna.cn
www.apexdyan.com



APEX DYNAMICS SHENZHEN, LTD.
TEL +86-755-84516325
NO.1102A of D area, CFG mansion, Bao Yuan
Road, Bao'an District, Shenzhen, CHINA.
sales@szapexdyna.com
www.szapexdyna.com



APEX DYNAMICS BEIJING, LTD.
TEL +86-10-69570691
NO. 1, Yao Ping Road, Song Zhuang Town, Tongzhou
District, Beijing, CHINA.
hjapexdyna@163.com
www.bjapex.cn



CHONGQING APEX DYNAMICS CO., LTD.
TEL +86-23-67686860
406, Building 5, NO. 68, Jinyu Avenue, Beibu New
Area, Chongqing, CHINA
sales@cqapexdyna.com
www.apexdyan.com



APEX (XIAMEN) DYNAMICS TECHNOLOGY CO., LTD.
TEL +86-0592-720-5279
Unit B-3, 1F., NO. 129, Jingquan Road, Jimei District,
Xiamen, Fujian, CHINA
sales@xmmapexdyan.com
www.xmapexdyan.com



APEX DYNAMICS USA, INC.
TEL +1-631-2449040
885 Marconi Avenue Ronkonkoma, NY 11779
U.S.A.
sales@apexdynamicsusa.com
www.apexdynamicsusa.com



APEX DYNAMICS KOREA INC
TEL +82-31-8179992
7-5, Aenigol-gil, Ilsandong-gu, Goyang-si, Gyeonggi-do,
Republic of Korea 10301
sales@apexdynakorea.co.kr
www.apexdynakorea.co.kr



APEX DYNAMICS JAPAN
TEL +86-092-4511202
1-3-46, Hannmichibasi, Hakata-ku, Fukuoka,
812-0897, JAPAN
sales@apexdyna.jp
www.apexdyan.jp



APEX DYNAMICS SINGAPORE PTE LTD
TEL +65-62-626228
3 South Buona Vista Road, #05-15 & #06-15.
SINGAPORE 118136
sales@apexdyna.sg
www.apexdyan.com.sg



APEX DYNAMICS (THAILAND) CO., LTD.
TEL +66-2-1812317
87 Soi Ladkrabang 30, Ladkrabang, Ladkrabang,
Bangkok 10520, Thailand
Apexthai2010@gmail.com
www.apexdyan.com



APEX DYNAMICS BV
TEL +31-492-509995
Churchillaan 101 5705 BK Helmond, NETHERLANDS
sales@apexdyan.nl
www.apexdyan.nl



**APEX DYNAMICS
POLSKA SP. Z O.O.**
TEL +48-12-6304728
Ul. Krakowska 50, 32-083 Balice, Poland
sales@apexdyan.pl
www.apexdyan.pl



APEX DYNAMICS SPAIN, S.L.
TEL +34-93-6562990
Carretera Laureà Miró, 407
08980 - Sant Feliu de Llobregat, Barcelona, SPAIN
apexdyan@apexdyna.es
www.apexdyan.es



Big Diamond Trading Company LLC
TEL +968-94268885
2nd floor, Regus, Tamimah building, Al
Wattayah, Muscat, Oman
ar.gorji@diamondtradings.com



APEKS DINAMIK REDUKTOR DISLI SAN TIC AS
TEL +90-232-4589960
10053 SOKAK NO: 9 A.O.S.B. CIGLI - IZMIR - TURKEY
sales@apexdyan.com.tr
www.apexdyan.com.tr



APEX DYNAMICS AUSTRALIA PTY LTD.
TEL +613-95-852739
36 Taunton Drive, Cheltenham, Victoria 3192
AUSTRALIA.
sales@apexdyan.com.au
www.apexdyan.com.au



APEX DYNAMICS (I) JV
TEL +91-9607927142
Shop No. 02, S. No. 100/5, Pune-Satara Highway,
Ambegaon Khurd, Pune-411046 Maharashtra, India
sales@apexdyan.co.in
www.apexdyan.co.in



APEX DYNAMICS FRANCE SAS
TEL +33-160-135097
11 - Burospace - 91570 - Bièvres, France
info@apexdyan.fr
www.apexdyan.fr



APEX DYNAMICS SWEDEN AB
TEL +46-75-2424444
Fredrikbergsgatan 2 SE-573 92 Tranås, SWEDEN
sales@apexdyan.se
www.apexdyan.se



PT.APEX DYNAMICS INDONESIA
TEL +62 21 2928 3681
Rukan Aralia Blok HY43 no.11, Harapan Indah II,
Bekasi - Jawa Barat, INDONESIA 17214
sales@apexdyan.co.id
www.apexdyan.co.id



APEX DYNAMICS GERMANY GMBH
TEL +49-7171 798069-0
Marie-Curie-Straße 25 D-73529 Schwäbisch Gmünd
werner.langer@apexdynamics.de
www.apexdynamics.de



APEX DYNAMICS CZECH S.R.O.
TEL +420-577-663877
tř. Tomáše Bati 1851 765 02 Otrokovice Česká
REPUBLIKA
info@apexdynaczech.cz
www.apexdynaczech.cz



APEX DYNAMICS РОССИЯ
TEL +7-495-2255452
TEL +7-495-6462422
г.Москва, ул. Южнопортовая, дом 7, строение
"С", 3-й этаж
info@apexdynarussia.ru
www.apexdynarussia.ru



APEX DYNAMICS MIDLANDS LTD
TEL +44-0121-737-1170
Heath House, Cheadle Rd, Uttoxeter,
ST14 7BY, UK
mikeg@apexdynauk.com
www.apexdynauk.com



APEX DYNAMICS SWITZERLAND AG
TEL +41-55-4517020
Obergasse 40, CH-8854 Galgenen, Switzerland
info@apexdyan.ch
www.apexdyan.ch



APEX DYNAMICS MOTION (M) SDN BHD
TEL +60 7267 4228
Block A1-2, #35-03, Mercu 1 Jalan Tanjung Puteri 1,
R & F Tanjung Puteri, Johor Bahru 80300, Johor.
sales@apexdyan.com.sg
www.apexdyan.com.sg



APEX DYNAMICS BRAZIL
TEL +55-47-30298700
Rua Senador Petrônio Portela, 47-Bloco 5, Zona
Industrial Norte-CEP 89218-575-Joinville (SC)
lucan@neoyama.com.br
adriano.duarte@neoyama.com.br
www.neoyama.com.br



APEX DYNAMICS ITALY SRL
TEL +39 02 36634521
VIA E. DE AMICIS, 2-20091 BRESSO (MI)
info@apexdynamics.it
www.apexdynamics.it



APEX DYNAMICS AUSTRIA GmbH
TEL +43 720788416
Dr. Hans-Lechner-Straße 6,
5071 Wals-Siezenheim
info@apexdynamics.at
www.apexdynamics.at



UAB "APEKSO DINAMIKA"
TEL +370 52078165
Medaus g. 28A,
Medininku k., Vilnius r. Sav.
LT-13192
info@apexdyan.lt
www.apexdyan.lt



APEX DYNAMICS DENMARK
TEL +45 73121260
Grundtvigs Allé 165, 6400
Sønderborg, Denmark
sales@apexdyan.dk
www.apexdyan.dk



APEX DYNAMICS ISRAEL
TEL +972-3-6470471
17 Hamefalsim St., Kiryat Arye,
Petach-Tikva 4951447
Sales@apexdynamics.co.il
www.apexdynamics.co.il



APEX DYNAMICS SLOVAKIA S.R.O.
TEL +421919400476
Trenčianska cesta 887/52, 957 01
Bánovce nad Bebravou, Slovak republic
office@apexdyan.sk
www.apexdyan.sk



APEX DYNAMICS, INC.

No.10. Keyuan 3rd RD.Situn District, Taichung City 40763, Taiwan (R.O.C)
Tel:886-4-24650219 | Fax:886-4-24650118
sales@apexdyan.com | <http://www.apexdyan.com>

APEX-2024-11-MGO/MGOH-SERIES-1.2-TWN

Printed in Taiwan



APEX DYNAMICS VIETNAM TRADING SERVICES CO., LTD
TEL +84-028-35350628
267 Duong so 7, P. Binh Tri Dong B, Q. Binh Tan,
Thanh pho Ho Chi Minh,Vietnam
Sales@apexdyan.vn
www.apexdyan.vn

